

SERVICE REFERENCE BOOK

of the MASTER TECHNICIANS SERVICE CONFERENCE

session no.

146

SUSPENSION AND FRONT-END ALIGNMENT FEATURES—1960 MODELS

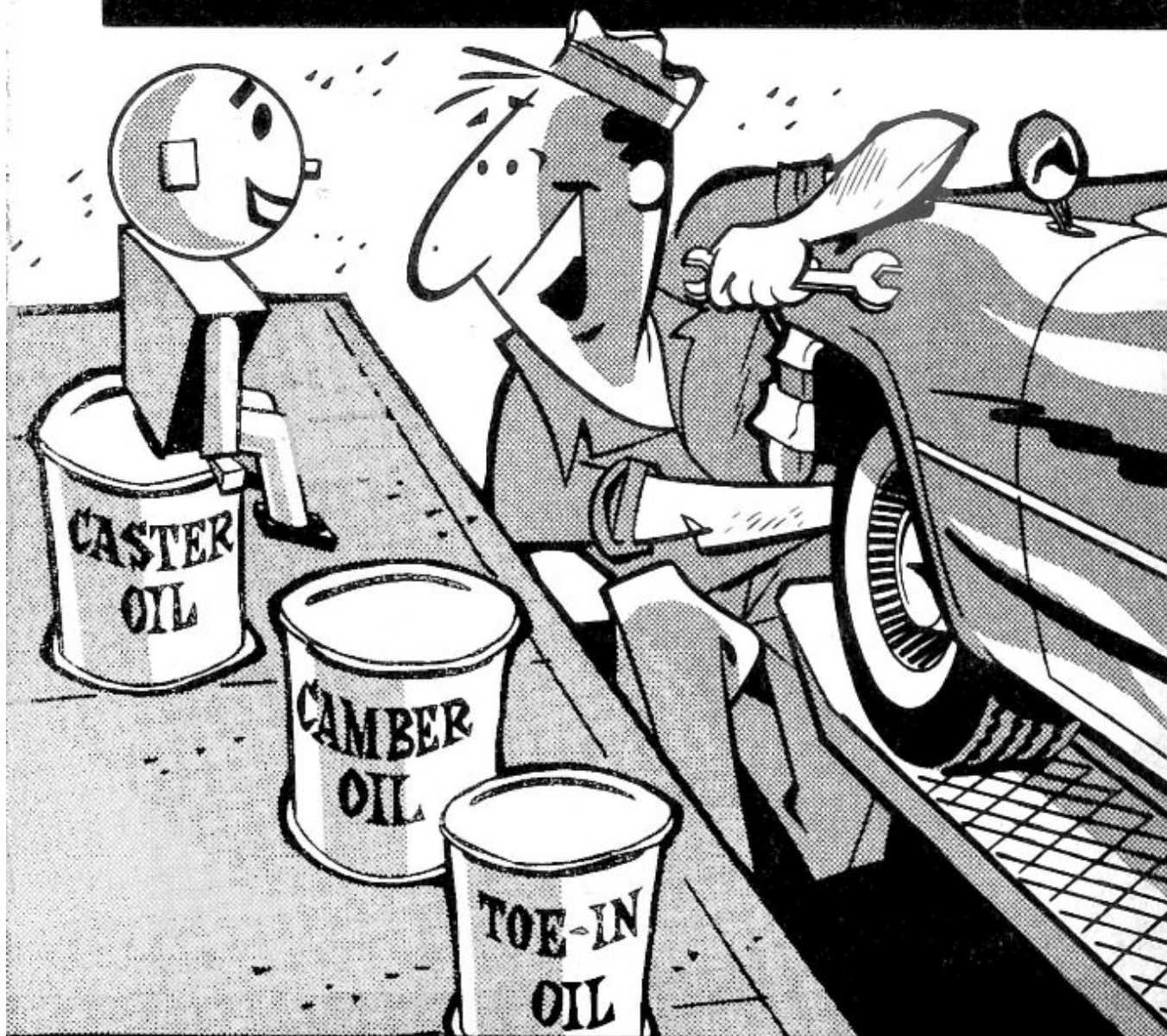

PREPARED BY CHRYSLER CORPORATION

Dodge • Plymouth-De Soto-Valiant • Chrysler and Imperial Divisions

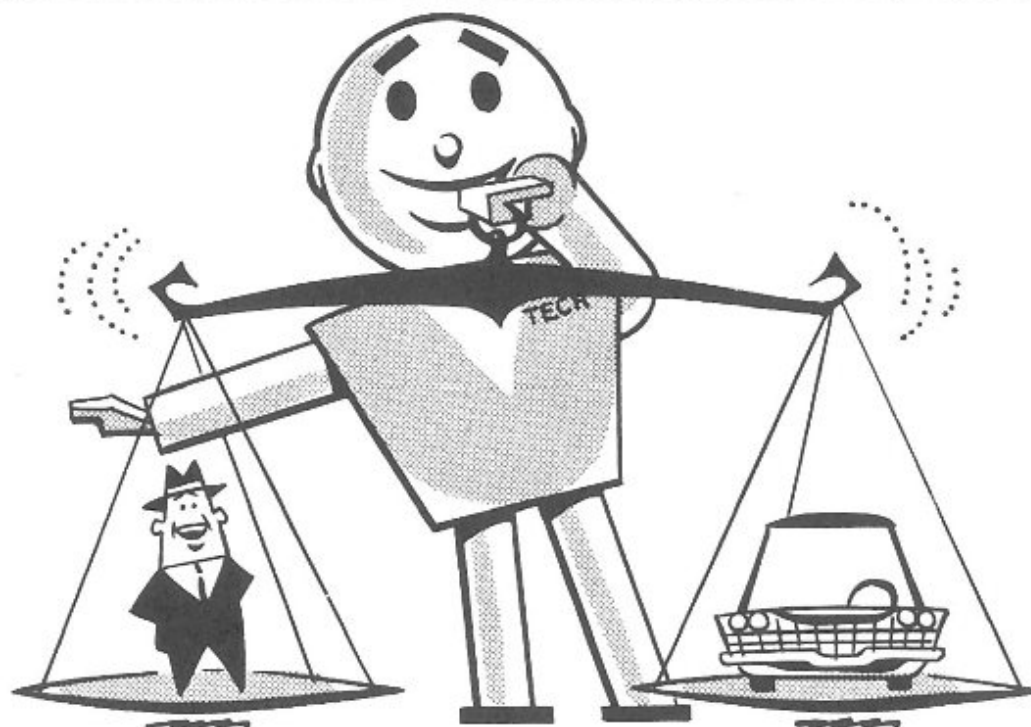

Tech sez: "For an owner's delight,
keep the suspension right!"

As a new-car owner, what would you expect in the way of riding characteristics? You'd be interested, certainly, in riding comfort—a car that drives smoothly, quietly, and handles with a minimum of effort. You'd also want good stability on curves, whatever the speed . . . safe, sure braking . . . and you'd want the new car to deliver good tire mileage.

Accurate suspension adjustments, of course, contribute to all of those driving characteristics. Since our 1960 models feature several improvements in suspension and steering system design, as well as in new body construction, it will pay to review the service procedures that have been affected.

This reference book outlines what's new, and how to maintain the suspension systems involved. Here's a handy index to the information:

	<i>Page No.</i>
EFFECT OF NEW CONSTRUCTION ON FRONT-END	
ALIGNMENT	4
Imperial	4
Chrysler, De Soto, Dodge, Plymouth	5
New Body Alignment Gauge	6
Valiant	6
FRONT SUSPENSION HEIGHT ADJUSTMENT	7
Use of Height Gauge	8
Valiant Ball Joint	11
Valiant Torsion-Bar Removal	12
ADJUSTING CASTER	12
Cars with Power Steering	12
Cars with Manual Steering	13
Unequal Caster	13
ADJUSTING CAMBER	14
Left Wheel	14
Right Wheel	14
Caster-Camber (Valiant)	15
STEERING AXIS INCLINATION	16
SPECIAL STEERING CONDITIONS	17
Car Steers Poorly	17
Suspension Noises	17
Shock Absorber Mounting	18
Control Arm Strut	19
Rubber Bushing Installation and Tightening	19
TOE-IN ADJUSTMENT	21
Valiant Steering Wheel Position	21
TOE-OUT ON TURNS	22
INSPECT REAR SUSPENSION PARTS	22
CONCLUSION	23

EFFECT OF NEW CONSTRUCTION ON FRONT-END ALIGNMENT

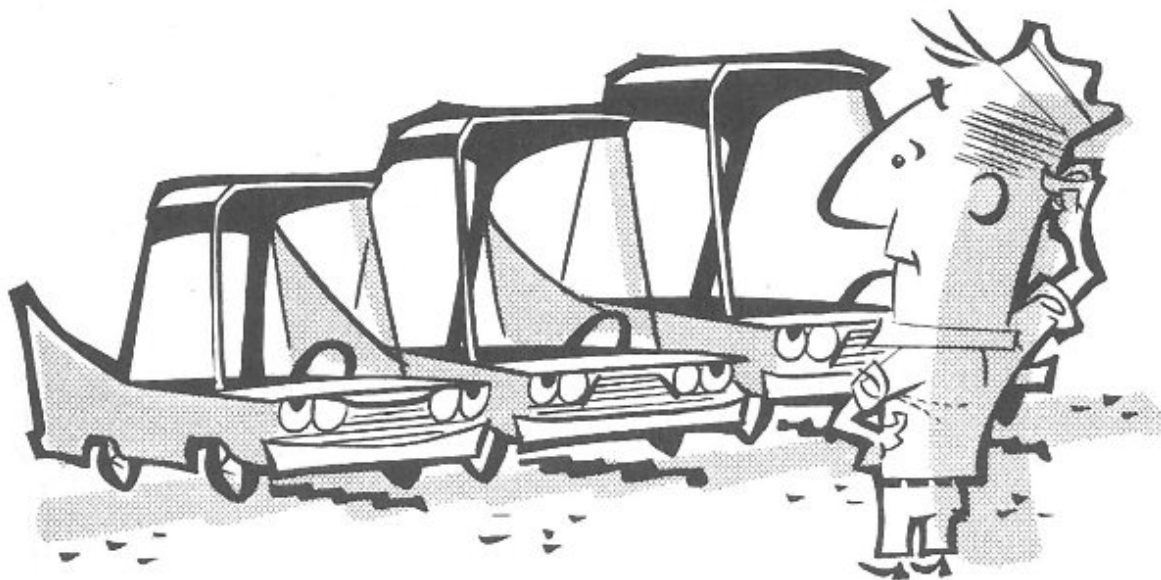

Our 1960 models feature three different types of construction. The Imperial uses a separate body and frame as in the past. Chrysler, De Soto, Dodge, and Plymouth cars use a new Unibody construction with a frame subassembly. The Valiant makes its bow with a *fully unitized* design.

Each construction, naturally, has some effect on suspension and front-end alignment service. Because any one of the new models might drive in for this type of attention at any time, each Master Technician should be familiar with the entire Chrysler product family.

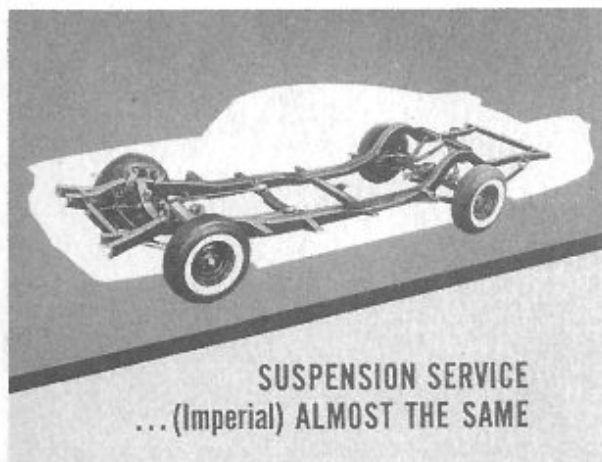

SUSPENSION SERVICE
... (Imperial) ALMOST THE SAME

IMPERIAL. The Imperial uses a separate frame and body, as in the past. Suspension service on the 1960 Imperial, therefore, is almost the same as on the 1959 model. There are some changes in specifications, though, that will be covered a little later.

CHRYSLER, DE SOTO, DODGE, PLYMOUTH. These models all feature the new Unibody. Box-section side members are integral with body members. A frame subassembly carries the front suspension, engine, and transmission. At its rear, this subassembly has a heavy-duty crossmember which is bolted rigidly to heavy box-section sills and body structural members. Frame subassembly side members are also rigidly bolted to the body at a heavily reinforced dash and cowl assembly.

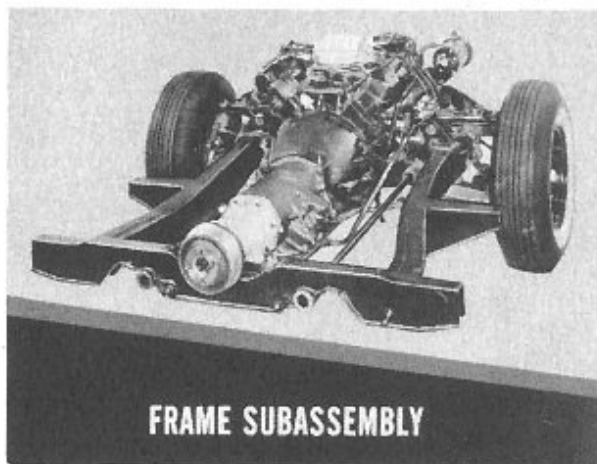

FRAME SUBASSEMBLY

Use of the new frame subassembly doesn't have a marked effect on suspension alignment because of the care taken in manufacture. Before the subassembly is bolted to the body, attachment points are under precise control. This assures proper front-to-rear and side-to-side alignment of the body-frame structure.

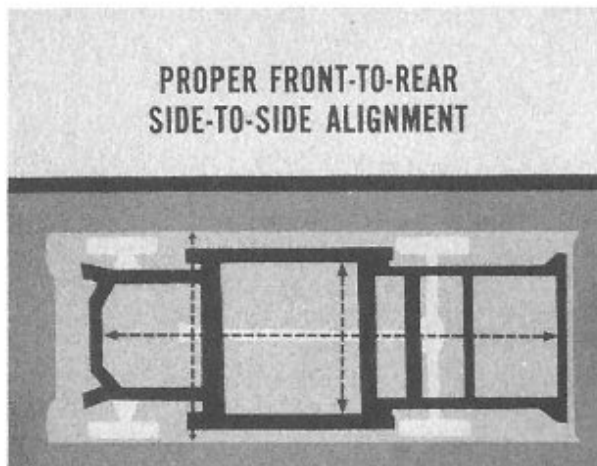

**PROPER FRONT-TO-REAR
SIDE-TO-SIDE ALIGNMENT**

Shims between the body and frame subassembly are used for proper up-and-down alignment as well as horizontal alignment at the front and rear. In manufacture, accurate gauges select the exact shimming needed. Unless you notice that the sheet metal is badly misaligned, there's no need to be concerned about body and frame subassembly alignment.

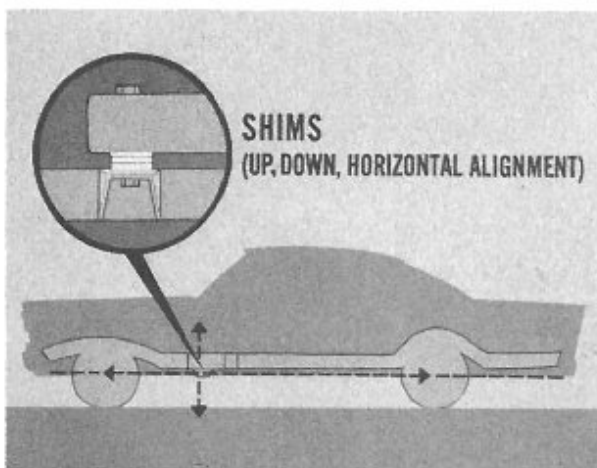

New Body Alignment Gauge. The only conditions under which a body-to-frame alignment inspection might be required would be when

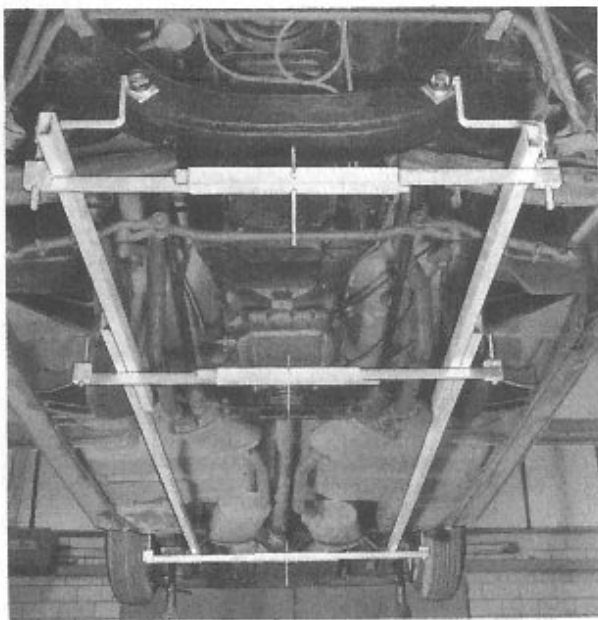

the frame subassembly had been removed, replaced, repaired, or when the front-end sheet metal cannot be properly lined up. To make this inspection, there's a new body alignment gauge (C-3802) available. It is supplied with complete instructions and chart that outline its use with the various wheelbases being produced. Also, reference points for alignment purposes are given in the service manuals.

In general, the four wheels on all of the 1960 models are always positioned in a true running plane, when the car travels straight ahead. Unless a car has been in a collision that causes misalignment, structural alignment won't be a factor in suspension and front-end service.

VALIANT. Construction on this new model is completely unitized. Body

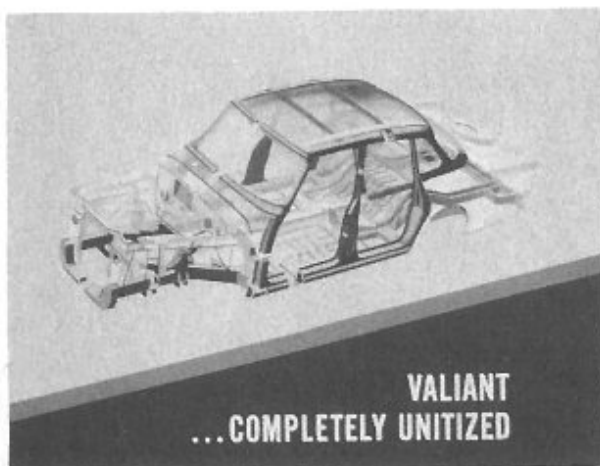

sills, pillars, roof rails, side, top and bottom panels are all parts of a fully unitized body-frame assembly. The only separate, bolted-on structure is a support for the engine front mounts and the front suspension lower control arms. It's called a "K-member" because of its distinctive shape.

The lower control arm pivot shaft and strut are attached to the legs of the K-member. The K-member, in turn, is bolted to the side members of the unitized body-frame.

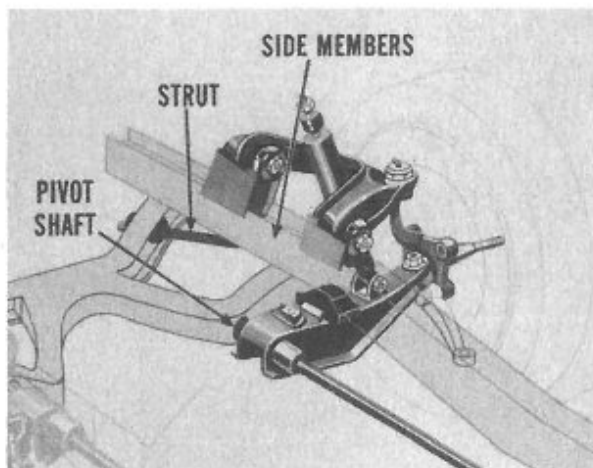

The torsion-bar front anchor, which is part of the lower control arm, provides a means of adjusting front-end height. The torsion-bar rear anchor is integral with the engine rear support member. While that's just opposite the way it appears on other models, it still provides the basis for adjusting suspension height.

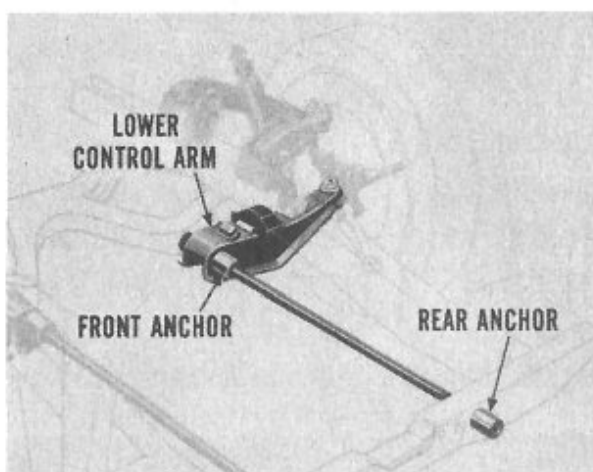

FRONT SUSPENSION HEIGHT ADJUSTMENT

Before taking wheel alignment measurements, be sure front-end suspension height is up to specifications. When measuring front-end height, there should be no load in the car, but the fuel tank should be full. You can add weight in the luggage compartment to make up for any lack of fuel. In case you have forgotten, one gallon of gas weighs six and one-half pounds.

Another important preliminary operation is the inspection of suspension and steering system parts for looseness, wear, or damage. Tires must be inflated to recommended pressure. The car should also be parked on a level floor.

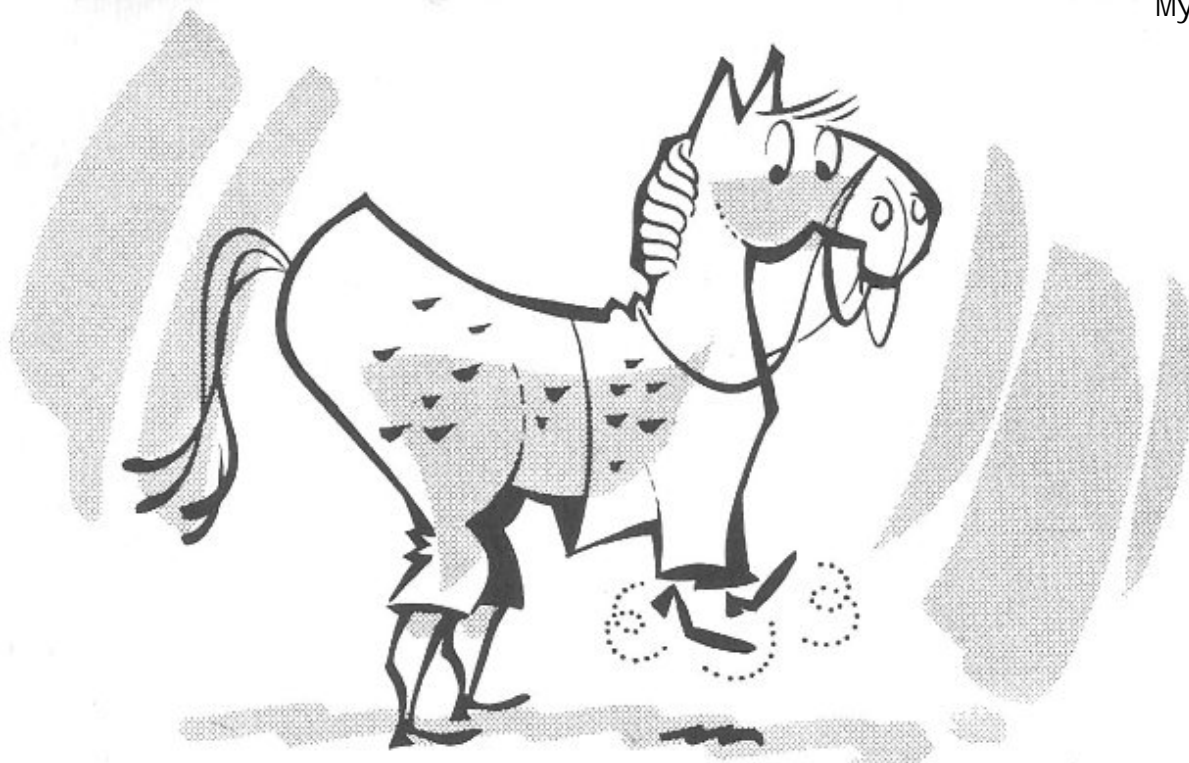

In addition, the suspension and springs must be at normal driving position before accurate measurements can be taken. So jounce the rear, then the front of the car by pushing down on the bumpers at their centers. Release each bumper on a downstroke after about five cycles. Do this before taking each measurement.

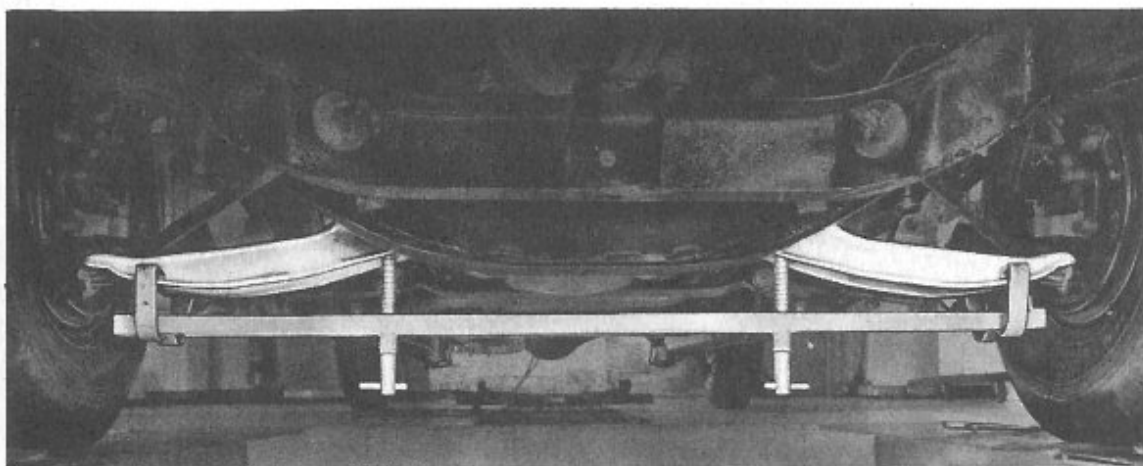

Use of Height Gauge. On all models, except the Valiant, you can use the same direct-reading height and level gauge (C-3608) you've been using. This gauge measures the difference in height between the underside of the lower ball joint and the underside of the lower control arm torsion-bar housing.

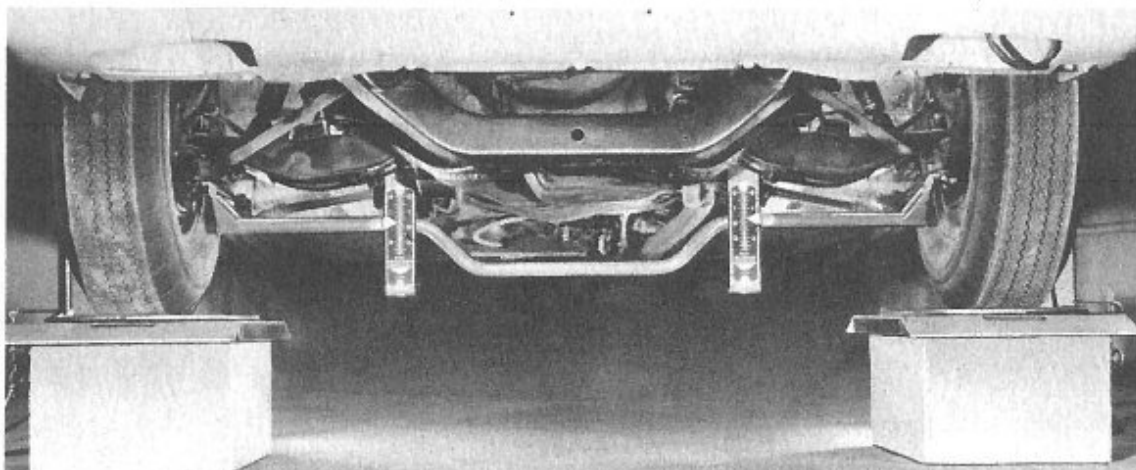

For the Valiant, there's a new height and level gauge (C-3738). The torsion-bar adjusting anchors are located at the front of the bar instead of at the rear, so the former gauge won't fit on the Valiant. After jouncing the car, you can adjust the torsion-bar anchors with this new gauge in place. But make sure the gauge is properly installed. It clamps around the torsion-bar housing right behind the lower control arms. It should be in contact with the bottoms of the lower ball joints, the bottoms of the torsion-bar housings, and the torque clips should rest against the bottoms of the torsion bars.

All 1960 models carry new front suspension height specifications. They appear in the table below:

MODEL	FRONT SUSPENSION HEIGHT
Sedans, Coupes (except Valiant)	2" \pm 1/8"
Suburbans, Cars with heavy-duty springs (except Valiant)	2 3/8" \pm 1/8"
Valiant, 4-door and Suburbans	1 3/4" \pm 1/8"

NOTE: Allowable difference between the left and right sides on all models is 1/8".

If one side isn't up to specifications, or if there is more than $\frac{1}{8}$ " difference between the sides, both sides must be adjusted. You'll have to loosen or tighten the adjusting bolts at both torsion-bar anchors. That's because changing the height on one side results in a height change on the opposite side.

Remember to recheck any new adjustments by jouncing the car, front and rear, and by taking new readings. Also, be sure the gauge is properly installed. It may move out of position when you jounce the car, and give an incorrect reading.

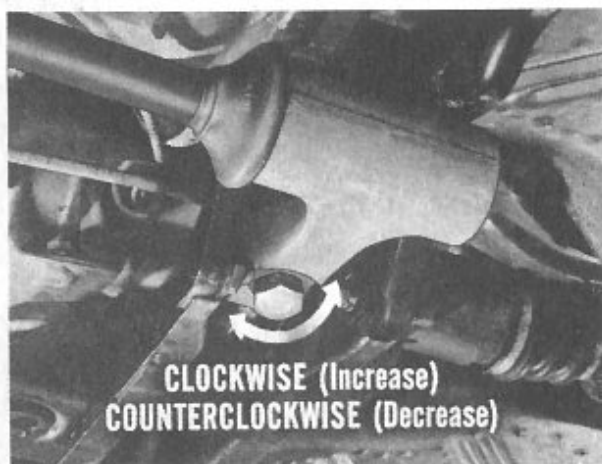

On cars with the frame sub-assembly, the torsion-bar anchors are inside the rear cross-member. Anchor adjusting bolts are located closer to the center of the car instead of toward the outside. You still turn them the same way, however — clockwise to increase height, counterclockwise to decrease height.

Use some penetrating lubricant (Part No. 1879318) on the threads before you adjust the anchor bolts. On all models, except Valiant, it shouldn't take more than 200 foot-pounds to turn the bolt. On Valiant, it shouldn't take more than 150 foot-pounds to turn the bolt.

CAUTION: If it takes more than the specified torque to turn an anchor bolt, let the front wheel hang down partially to relieve some of the load on the torsion bar. Then, replace the anchor bolt and swivel on all models, except Valiant. On Valiant, you'd replace the T-bolt and nut.

Another thing . . . use multipurpose chassis lubricant to pack the rubber seal at the torsion-bar rear anchor as a safeguard against rust and corrosion.

Valiant Ball Joint. On the Valiant, by the way, the lower ball joint is a compression-type rather than a tension-type joint. The ball stud attaches to the lower control arm. The ball socket part attaches to the steering knuckle arm and support. Because the Valiant joint is a compression type, and because it uses a balloon-type seal that puts no preload on the ball, the ball will feel loose in its socket when car weight is off the front wheels. If you didn't know that, you might jump to the conclusion that the ball joint was excessively loose and in need of replacement.



So, especially on the Valiant, inspect ball joints for looseness only when the car weight is on the wheels. This is a sound practice to observe when checking for ball joint looseness on all models.

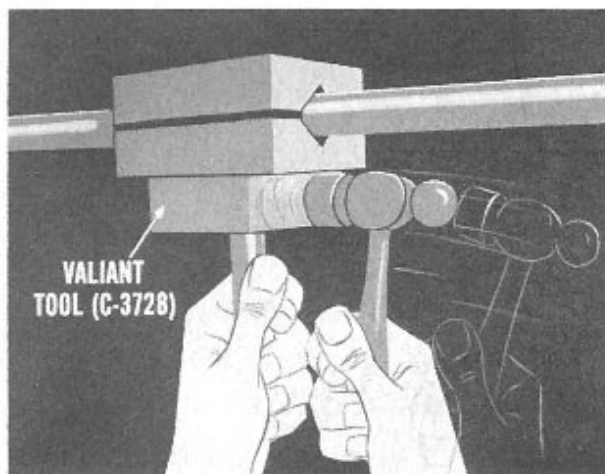

Valiant Torsion-Bar Removal. If you should find it necessary to remove a Valiant torsion bar, be sure to use the special clamp-on tool (C-3728) available. It permits you to drive the bar out through the rear anchor. Never pound on the end of the bar.

ADJUSTING CASTER

Once a car has the proper front-end adjustment it will handle better, brake more effectively and deliver more miles from a set of tires. Caster and camber specifications are new on all 1960 models.

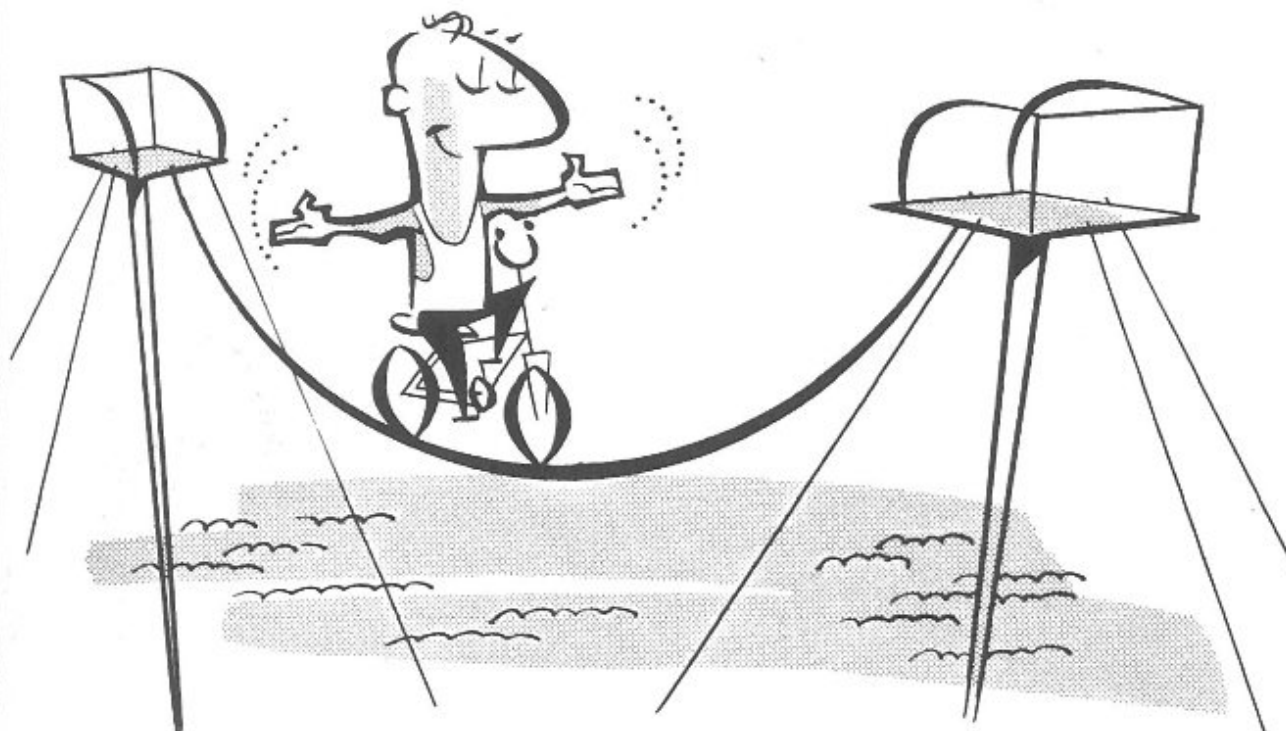

Cars with Power Steering. Caster, especially, must be set to much closer tolerances. On a car with power steering, caster should be a

positive $\frac{3}{4}^\circ \pm \frac{1}{2}^\circ$, with a positive $\frac{3}{4}^\circ$ preferred. This applies to both left and right wheels — and on *all* models. Positive $\frac{3}{4}^\circ$ caster is preferred on cars equipped with power steering because it increases directional stability. It also helps the wheels return after they roll around a turn.

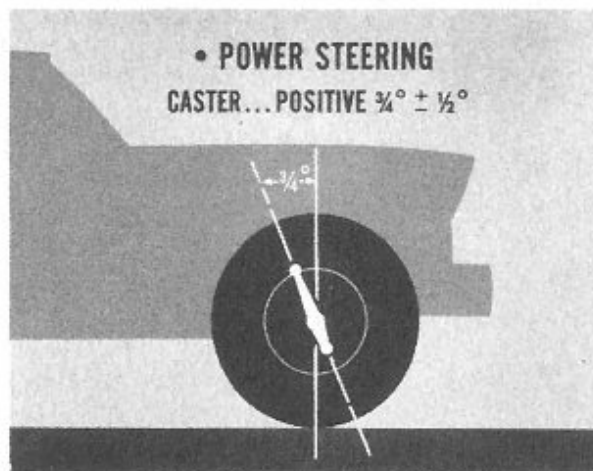

If a car with power steering had too much positive caster, it could show up as a shimmy—especially when the car had a high passenger load.

Cars with Manual Steering. Caster on a car equipped with manual steering should be negative $\frac{1}{2}^\circ \pm \frac{1}{2}^\circ$. A negative $\frac{1}{2}^\circ$ caster is preferred. Again, this applies to both left and right wheels, and to all models. In this case, negative $\frac{1}{2}^\circ$ caster is preferred because it reduces steering effort, especially at low speeds. Too much positive caster on a manual steering car will show up as a case of hard steering.

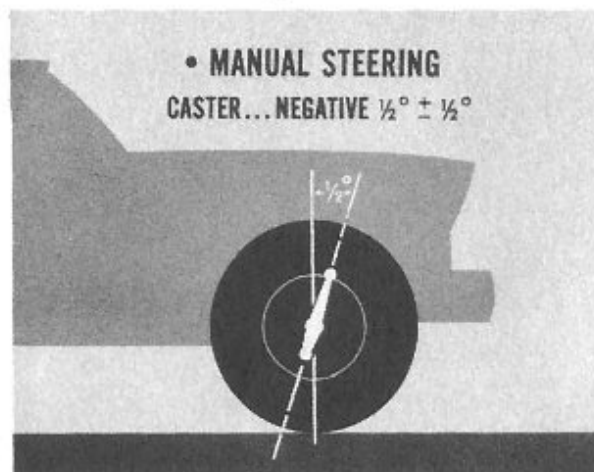

Unequal Caster. Unequal caster will make a car tend to drift toward the side with the least amount of positive caster. If there's too much difference in caster, the car may pull toward one side when the brakes are applied.

Pulling to one side is even more apt to happen when one wheel has negative caster and the other has positive caster. The car will try to go toward the side with negative caster when brakes are applied.

ADJUSTING CAMBER

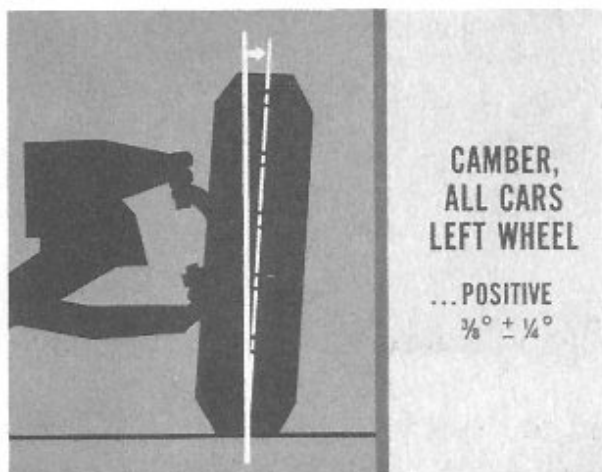

Left Wheel. There are new camber specifications for 1960 and they apply to all of the new cars. On the left wheel, camber should be a positive $\frac{3}{8}^{\circ} \pm \frac{1}{4}^{\circ}$. A positive $\frac{3}{8}^{\circ}$ camber is preferred.

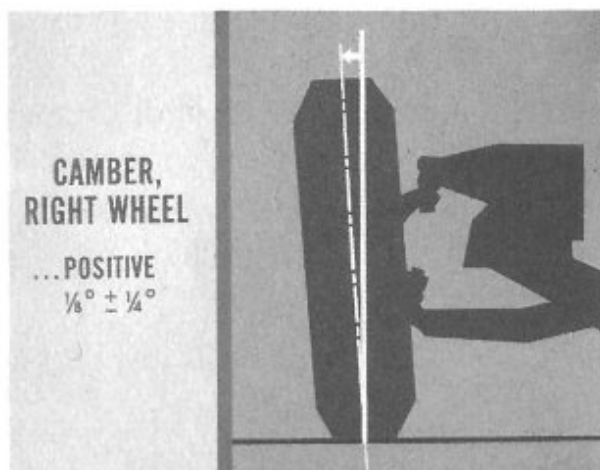

Right Wheel. On the right wheel, the camber angle should be a positive $\frac{1}{8}^{\circ} \pm \frac{1}{4}^{\circ}$. A positive $\frac{1}{8}^{\circ}$ camber is preferred. Proper camber, as you know, is mighty important to good, normal tire life.

While caster and camber specifications are new, you still use the

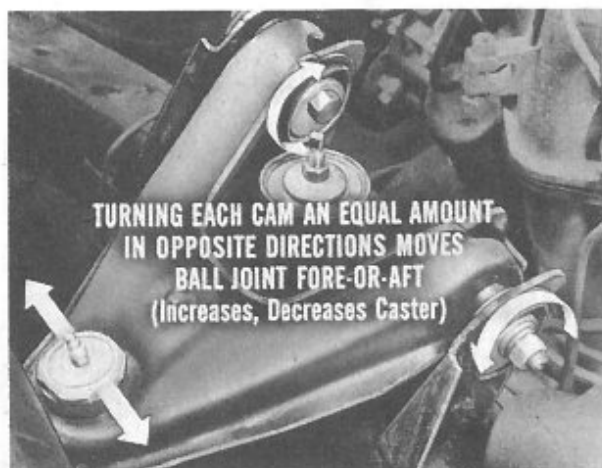

same method of adjustment. But just by way of a reminder, here are some tips that still apply. Turning each cam bolt an *equal* amount, but in *opposite* directions, moves the ball joint end of the upper control arm forward or rearward. This movement increases or decreases caster.

Turning both the front and rear cam adjusting bolts an *equal* amount, but in the *same* direction, moves the upper control arm toward the center of the car, or away from the center. This movement increases or decreases camber.

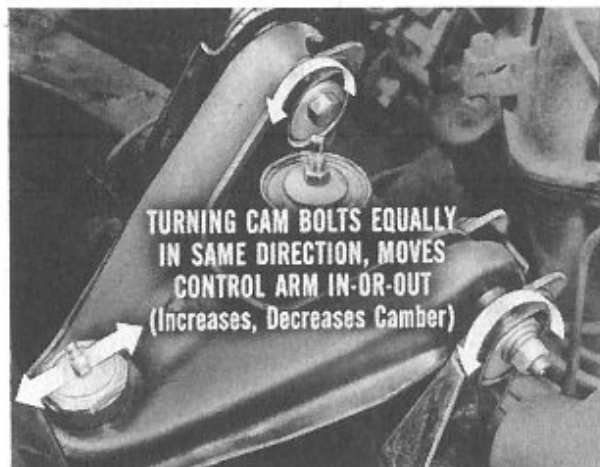

Caster-Camber (Valiant). On the Valiant, you can't get at the cam bolts and lock nuts by way of the engine compartment. You'll have to reach over the tire, or from underneath, to adjust caster and camber on these models.

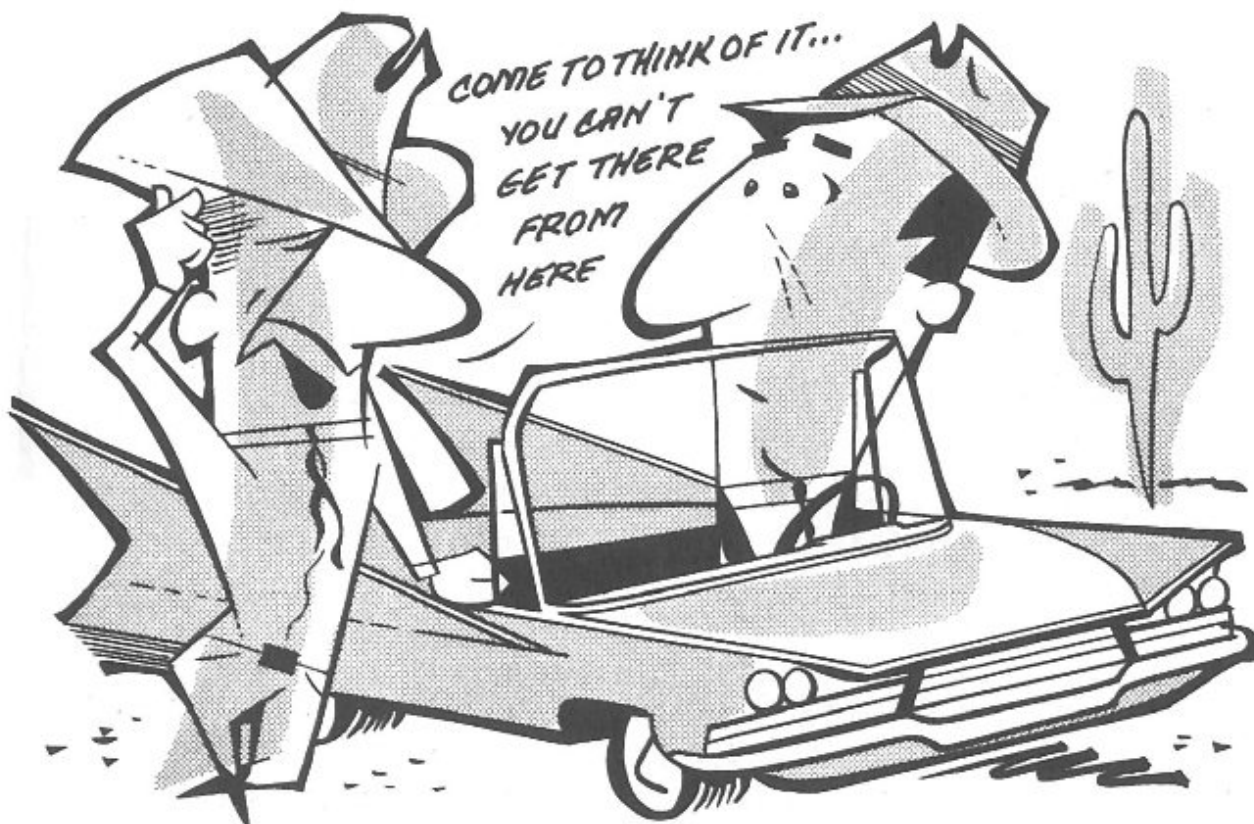

Here's something else. The front cam bolt on the Valiant model must be installed from the rear, and the rear bolt from the front. Cam bolt heads must be next to each other between the front and rear

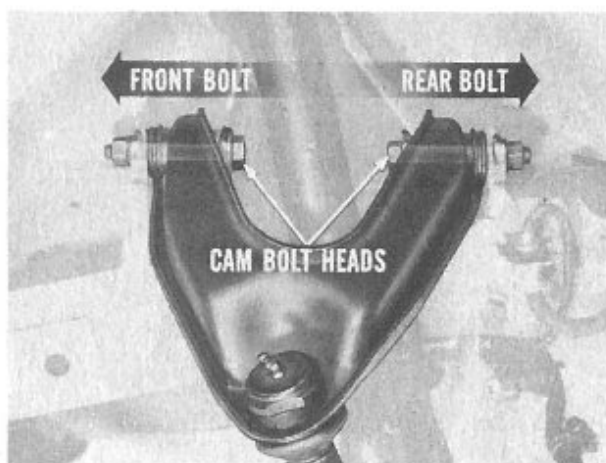

upper control arm bushings. If you install them any other way, you won't be able to adjust the cams and tighten the lock nuts correctly. Torque specification on the lock nuts is 65 foot-pounds. This is necessary to prevent cam slippage and changes in a carefully set adjustment.

STEERING AXIS INCLINATION

The angle of steering axis inclination is designed into the steering knuckle, and is not adjustable. But you should measure the angle to detect bent parts, or whenever you have difficulty meeting camber specifications. Such a case might indicate a bent support arm.

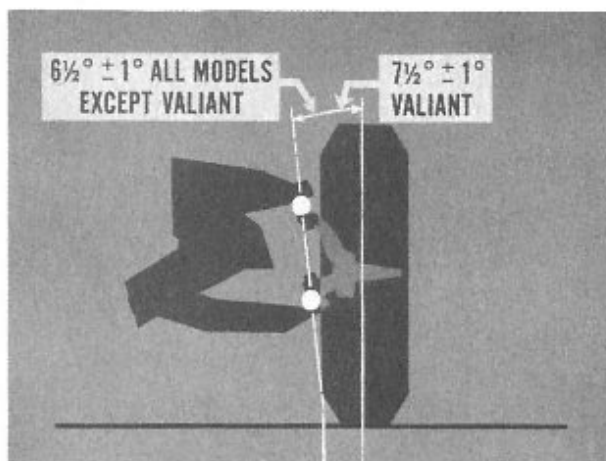

On all models, except Valiant, steering axis inclination should measure $6\frac{1}{2}^{\circ} \pm 1^{\circ}$. On the Valiant, this angle should measure $7\frac{1}{2}^{\circ} \pm 1^{\circ}$.

Steering axis inclination is a big factor in giving the car directional stability. In fact, it does more for directional stability than caster does. That's one reason why negative caster can be used with manual steering to reduce turning effort, without sacrificing directional stability.

NOTE: Never try to change caster angles to improve steering until you know steering axis inclination is correct.

SPECIAL STEERING CONDITIONS

Car Steers Poorly. If all the angles check out according to specifications, but the car still steers poorly, here's where to look for the possible cause. Inspect for loose, worn, or binding suspension or steering parts. In addition, take a close look at the rear spring "U-bolts" for possible looseness.

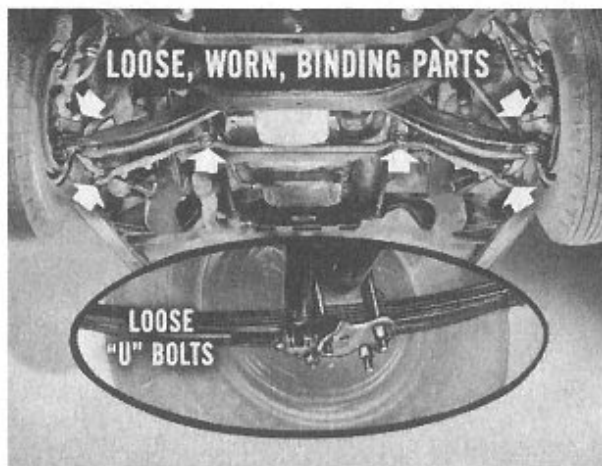

Suspension Noises. Noises probably annoy car owners more than any other condition. That's why rubber bushings are used throughout the suspension and steering systems. So take a good look at the rubber isolation used at the strut pivot, the lower and upper control arm pivots, and at the jounce and rebound bumpers.

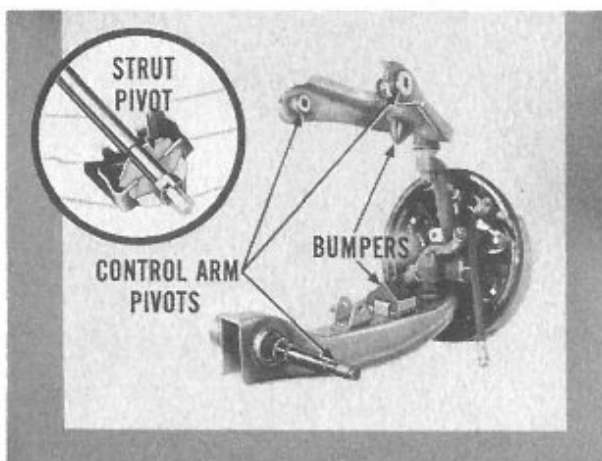

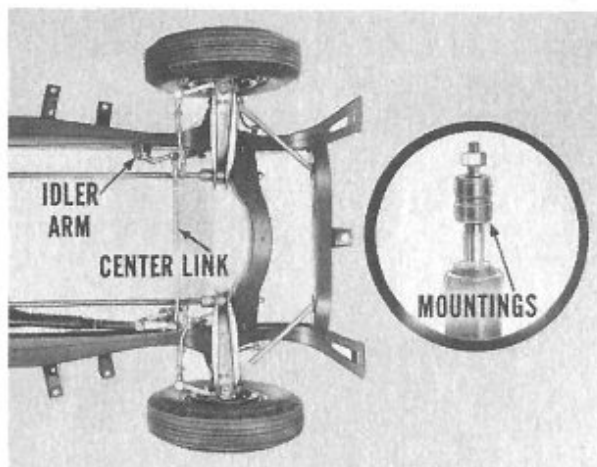

Besides those points, inspect the rubber isolation points at the idler arm, at the center link, at shock absorber mountings, at sway bar mountings, and so on. Periodic inspection of these points will serve as a good check against noise.

Shock Absorber Mounting. On early 1960 production cars, you might



find that threads on the lower shock absorber mounting bolt are not long enough. In a case like this, the nut will bottom on the threads. So, even though you might tighten the nut to its specified 55 foot-pounds, the mounting may still be loose and cause noise.

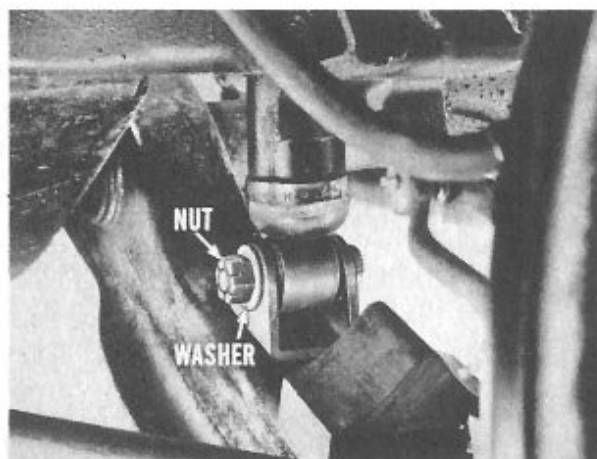

That will sound very much like a faulty shock absorber, so don't be fooled. Instead of replacing the shock, remove the nut and install a flat washer as a spacer to keep the nut from bottoming. Be sure the rear shock *upper* mounting stud is tight in the body, too.

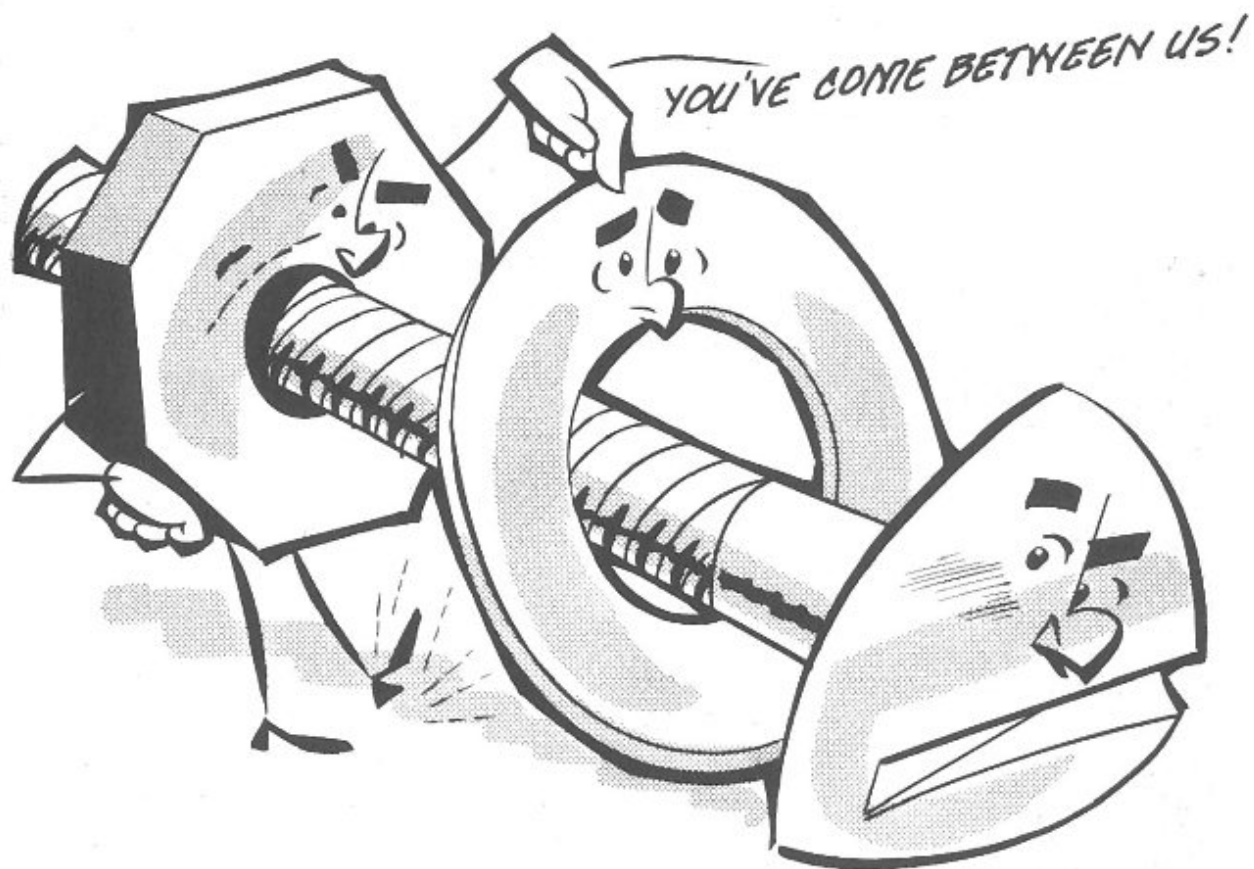

Control Arm Strut. Another point is to make sure the rubber bushing at the front end of the strut is in good condition. Also, see if you get exactly 40 foot-pounds when you put a torque wrench on the strut nut. A loose or improperly installed strut can affect handling and braking, and will also cause noise. Properly tightened, the control arm strut will brace the lower control arm under drive and braking loads.



Rubber Bushing Installation and Tightening. Rubber-bushed parts must be assembled and tightened to their specified torques while they're in a normal driving position. As an example, take the lower control arm bushing. This

must be tightened to its specified torque after you install it, and while the control arms are in a normal “curb-height” position. If you don’t do that, you’ll *preload* the bushings. For example, let’s say the sus-

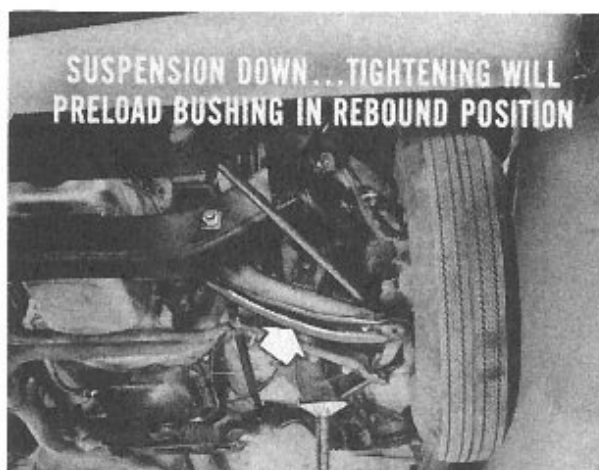

pension assembly hangs down when you tighten the bushing shaft. That would preload the bushing in *rebound* position. This will affect ride and tend to reduce the life of the bushing. Rapid changes in car height can also take place as rubber parts try to relieve their stress by “rubber creep”.



Here’s another example. If you tighten the idler arm bushing with the wheels *turned*, it will preload the bushing in that position. So, tighten rubber-bushed steering parts only when the wheels are in straight-ahead position.

A bushing tightened in a stressed position can cause a drift, unequal steering effort, and can affect wheel returnability. What’s more . . . any loose attachment, or improperly tightened part can cause noise and otherwise detract from good ride and steering qualities. A loose rear shock mounting, or a squeaking steering column seal can annoy even the most loyal owner.

NOTE: If you have to assemble new rubber suspension parts, use only clear water to facilitate assembly. No other lubricant is recommended!

TOE-IN ADJUSTMENT

Toe-in specifications and adjustment procedures are unchanged for 1960 models. You still adjust toe-in to $\frac{1}{8}$ " , and you do it the way you always have. Some reminders, however, might be helpful. For instance, center the steering wheel. Keep the tie-rod clamp bolts *below* the tie rods so that they will clear other suspension and body-frame parts when the road wheels are turned.

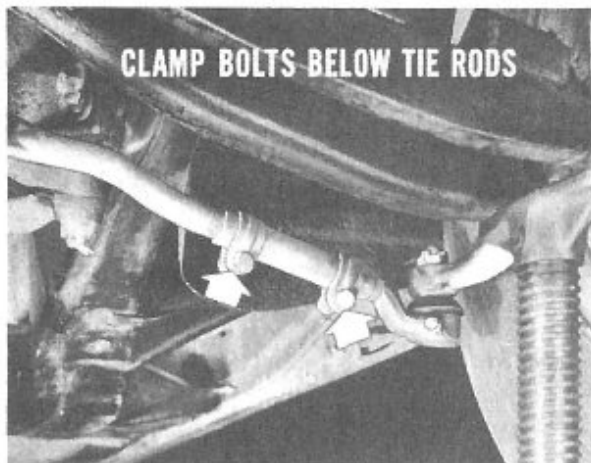

And, before you tighten the clamp bolts, rotate the tie rod and its ball ends so that all free motion between ball studs and sockets is taken up in the same direction. This will permit ample tie-rod movement on all turns and will prevent any binding at the sockets.

Valiant Steering Wheel Position. There is no master spline on the Valiant steering shaft for locating the steering wheel. Here's how to set the wheel in its proper, straight-ahead position if you find one

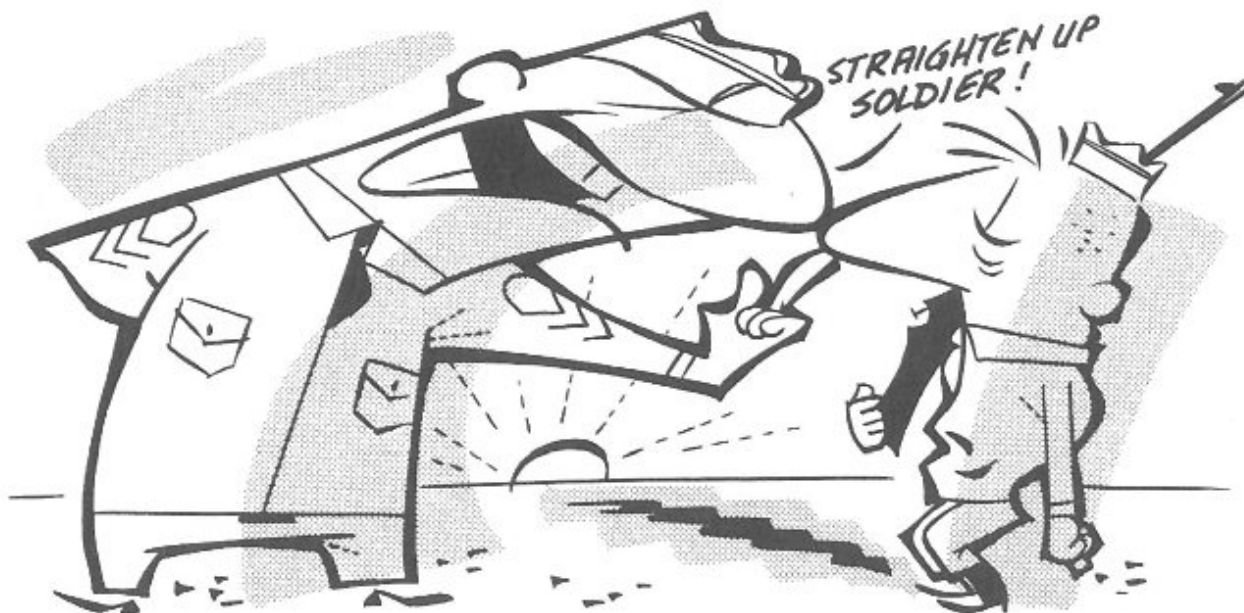

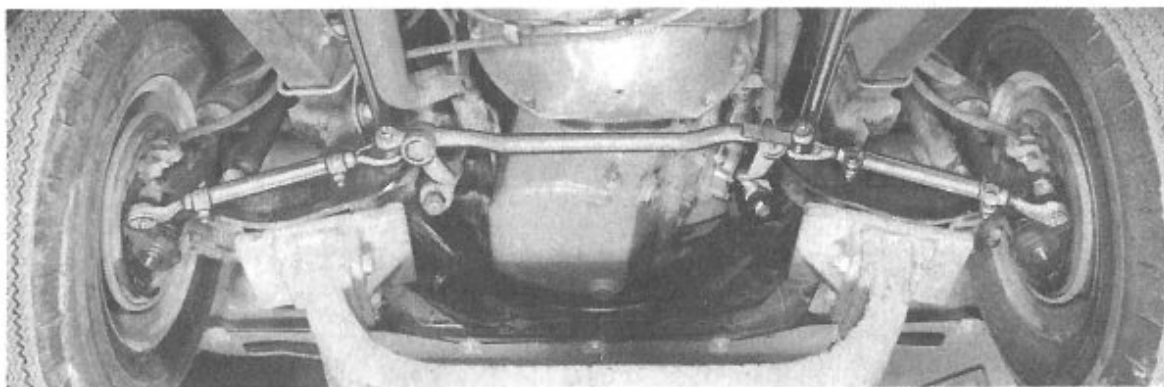

that is not correct. See that Valiant front wheels are straight ahead. Then, measure from the torsion bars to each end of the center tie rod to determine how well the rod is centered. If it isn't centered, adjust the ball ends until it is. Next, relocate the steering wheel on the steering shaft to place the wheel in normal straight-ahead position. If the center tie rod isn't centered, the car may tend to pull left or right on bumpy roads.

TOE-OUT ON TURNS

Toe-out on turns is built in and cannot be adjusted. Measure it,

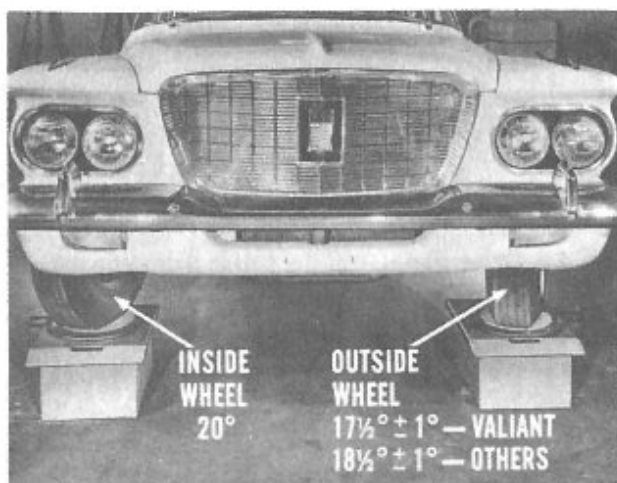

though, as a check for bent steering parts. On the Valiant model, when the inside wheel is turned 20°, the outside wheel angle should be 17½° ± 1°. On all other models, when the inside wheel is turned 20°, the outside wheel angle should measure 18½° ± 1°.

INSPECT REAR SUSPENSION PARTS

Remember to cast an eagle eye over the rubber parts involved in the rear suspension system. Examine the rear shock mountings, rear shackles, jounce and carrier nose bumpers, and spring interliners. Replace any part that appears to be worn excessively.

CONCLUSION

Nobody needs to remind you that a properly adjusted suspension system is appreciated by your service customer. And because so many riding and steering qualities depend on correct front suspension height, proper caster-camber settings, toe-in, steering axis inclination . . . these adjustment points deserve your most careful attention.

So follow the 1960 suspension and front-end alignment specifications covered in this reference book. It will provide your customer with a car that handles better, rides quieter and more comfortably, brakes more effectively, and gets maximum tire life. All of this adds up to greater customer satisfaction with his Chrysler-made product, and increases his confidence in your service ability.

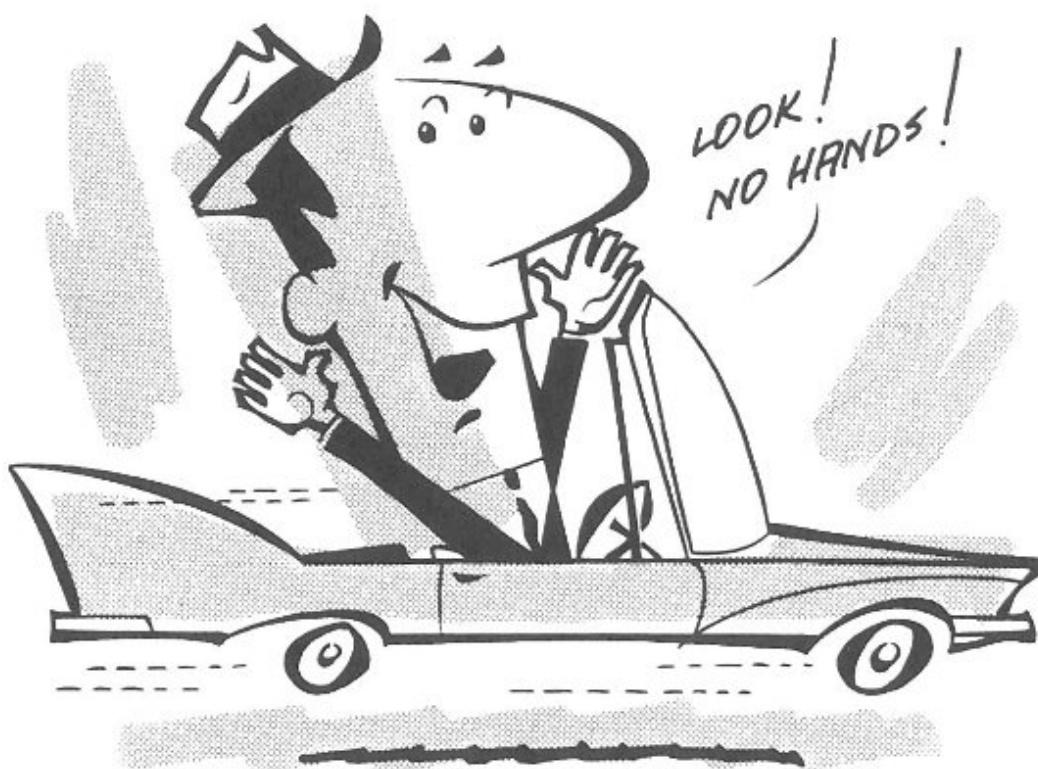

RECORD YOUR ANSWERS TO THESE QUESTIONS ON QUESTIONNAIRE NO. 146

- | | | | |
|---|--------------------------------|----|--------------------------------|
| You adjust the torsion-bar anchor bolts at the rear of the bar on all models. | <input type="radio"/>
RIGHT | 1 | <input type="radio"/>
WRONG |
| Front-end height should be measured without passengers, but with a full tank of gas or its equivalent weight in the luggage compartment. | <input type="radio"/>
RIGHT | 2 | <input type="radio"/>
WRONG |
| Jounce the car at the rear, then front, for about five cycles before taking any suspension measurements. | <input type="radio"/>
RIGHT | 3 | <input type="radio"/>
WRONG |
| The same height and level gauge is used on all models. | <input type="radio"/>
RIGHT | 4 | <input type="radio"/>
WRONG |
| Allowable difference in suspension height between left and right sides on all models is $\frac{1}{8}$ ". | <input type="radio"/>
RIGHT | 5 | <input type="radio"/>
WRONG |
| Use multipurpose chassis lubricant to pack the rubber seal at the torsion-bar rear anchor as a guard against rust and corrosion. | <input type="radio"/>
RIGHT | 6 | <input type="radio"/>
WRONG |
| Never pound on a torsion bar to remove it. | <input type="radio"/>
RIGHT | 7 | <input type="radio"/>
WRONG |
| Before you tighten any rubber-bushed mountings, see that all parts are in a normal, straight-ahead, driving position to avoid any preloading. | <input type="radio"/>
RIGHT | 8 | <input type="radio"/>
WRONG |
| When assembling new rubber suspension parts, use only clear water to facilitate assembly. | <input type="radio"/>
RIGHT | 9 | <input type="radio"/>
WRONG |
| The toe-in specification on all 1960 models is $\frac{7}{8}$ ". | <input type="radio"/>
RIGHT | 10 | <input type="radio"/>
WRONG |