

SERVICE REFERENCE BOOK

of the MASTER TECHNICIANS SERVICE CONFERENCE

session no.

159

Steering and Suspension Service Tips

**Prepared by CHRYSLER CORPORATION
PLYMOUTH, DODGE, CHRYSLER-IMPERIAL DIVISIONS**

TECH SEZ:

"Good steering and suspension



	<i>Page No.</i>
POWER STEERING	4
GENERAL	4
PUMP	5
Replacing Pump Seals	7
LUBRICATION SPECIFICATIONS	8
DIAGNOSING POWER STEERING TROUBLES	9
Pressure Tests	10
Sticky Steering and Wandering	16
Oil Leak—Cross Shaft Oil Seal Snap Ring	18
Chuckling Noise	19
MANUAL STEERING	22
HARD STEERING AND WANDERING— VALIANT AND LANCER	22

operation is like riding on a cloud"

Your owners, particularly those who operate cars equipped with Constant-Control Power Steering, depend upon this equipment to make driving easier and more enjoyable. Power steering, coupled with Torsion-Aire suspension, gives owners of Chrysler-built cars the finest in steering and riding comfort.

You, as a Master Technician, are expected to quickly and correctly diagnose any steering or suspension troubles encountered and make the necessary repairs at the lowest possible cost. Information outlined in this reference book can help you do just that.

Here's how the information is arranged:

	Page No.
FRONT SUSPENSION	23
BALL JOINT SEALS—	
VALIANT AND LANCER	23
TORSION BARS—	
VALIANT AND LANCER	24
TORSION BARS—ALL MODELS	26
FRONT-END ALIGNMENT	26
CAR HEIGHT—VALIANT AND LANCER	27
RUBBER BUSHINGS	27
REAR SHOCK ABSORBERS—	
PLYMOUTH, DODGE, DE SOTO AND CHRYSLER	28
NEW-CAR STEERING INSPECTION PROCEDURE	28
CONCLUSION	30

POWER STEERING

General

In a hydraulic system, such as used in the power steering unit and pump, various types of seals are used to retain the fluid under pressure in internal areas and prevent external leaks.

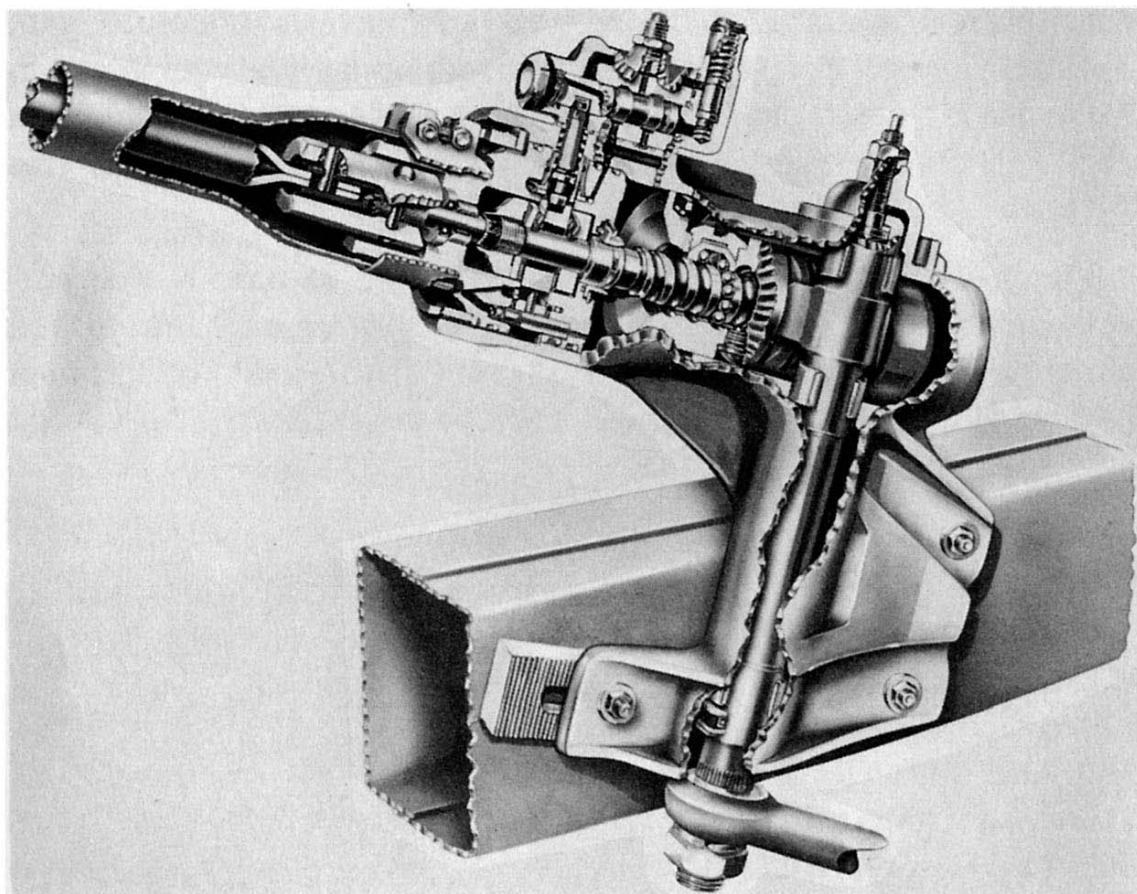

Seals, like all other parts, eventually wear or deteriorate. When this happens, fluid under pressure may leak out externally, or may escape internally into different pressure areas. Replacement of seals to correct an external leak is, in most instances, a minor operation. However, due to failure to correctly diagnose an apparent fluid leak or malfunction of the gear, power steering pumps and gear units

have sometimes been needlessly replaced. Therefore, a careful diagnosis of the condition reported by the owner is the technicians' responsibility to the owner, the dealer and himself.

Pump

The power steering pump is provided with two seals—a lip-type seal used at the front end of the rotor shaft, and a large “O”-ring seal under the edge of the reservoir.

On numerous occasions, pumps have been replaced for an apparent leak when, actually, the presence of fluid on the outside of the pump was not due to a leak but to the fluid being forced out of the pump through the vent in the reservoir filler cap.

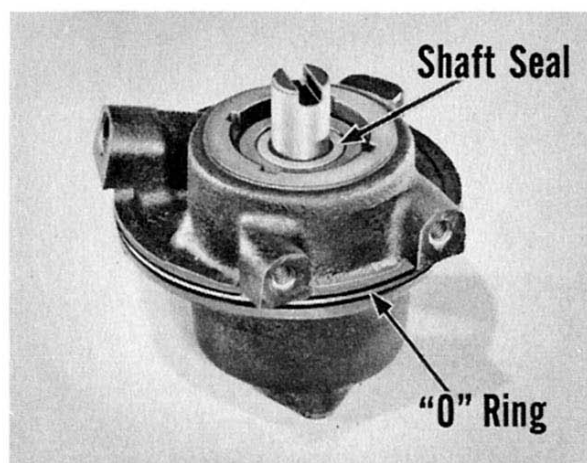

For various reasons, cars may be moved about with the engine not running. If the car must be steered during this period when the fluid is not being circulated normally through the steering system, the piston may force the fluid up into the reservoir. Since the pump is not operating, the fluid level is raised, forcing the fluid out through the vent hole in the filler cap. This lowers the fluid level in the system and, if it occurs repeatedly, the loss of fluid can affect the operation of the gear.

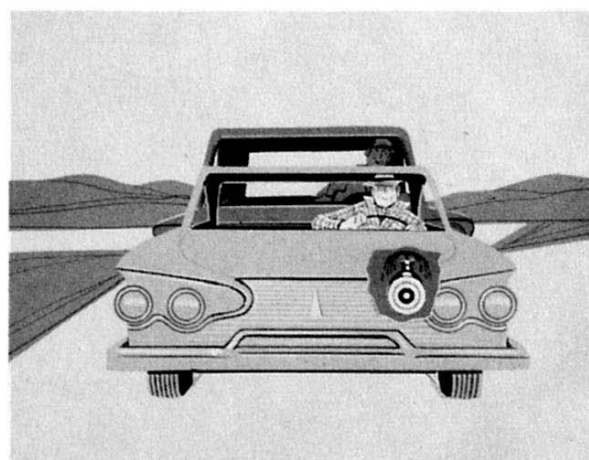

An owner, of course, does not understand these conditions, and his first conclusion is that a fluid leak in the hydraulic system is the cause of the trouble.

In such cases, the cause of fluid overflow should be explained to the owner, and he should be assured that the pump is not in need of repair.

To determine whether the pump is actually leaking, carefully wipe

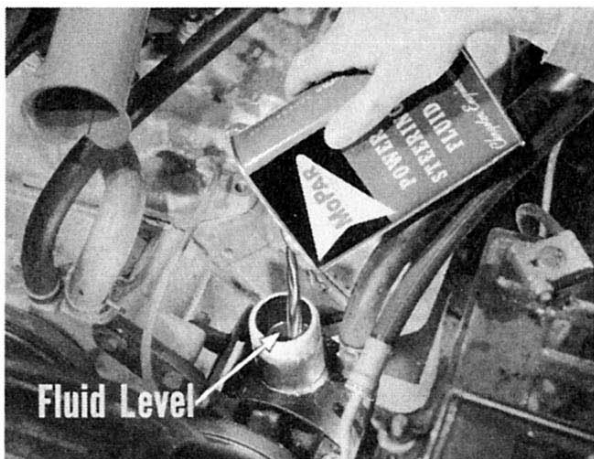

off the pump. Then, add sufficient Power Steering Fluid (Part Number 2084329) to the reservoir to bring the level up to the bottom of the filler neck, if the fluid is *cold*. When the fluid is *warm*, the level should be about halfway up the neck.

Wipe off the pump to remove any traces of fluid which might have spilled on the pump during the filling operation. Start the engine and turn the steering wheel from one extreme to the other, several times, to expel all air from the system. Re-examine the level and add fluid, if necessary, to restore the level. Carefully examine the shaft seal, and the seal area of the reservoir for evidence of fluid leakage.

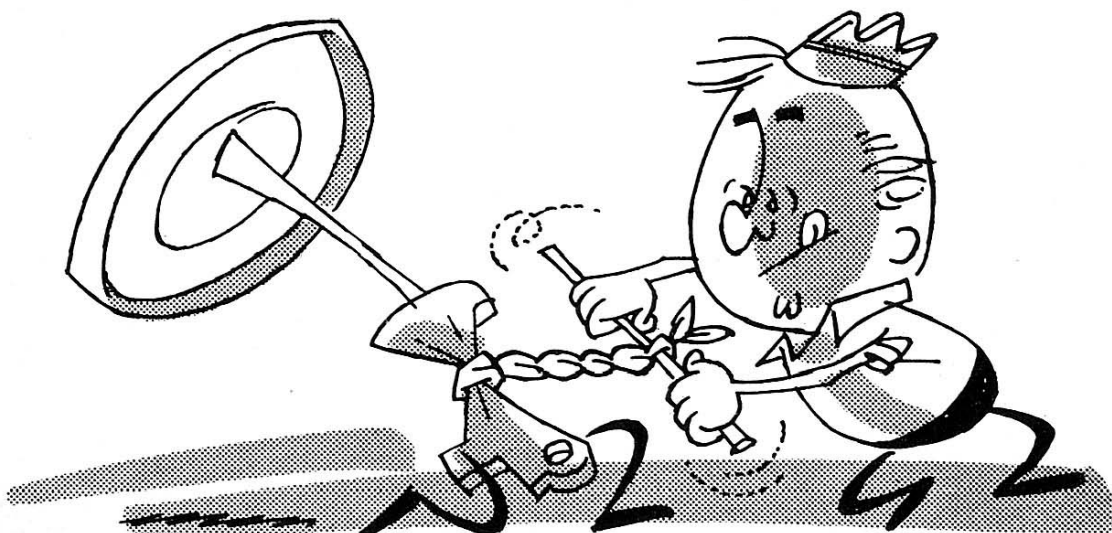

If, after a reasonable period of operation, there is no evidence of leakage from the pump, it can be assumed the condition reported was due to overflow of fluid from the reservoir.

On the other hand, if leakage is observed at either the shaft seal or the reservoir "O"-ring areas, the pump should be removed for repairs. These seals can be replaced separately. In fact, all external leaks can usually be repaired. It is not necessary to replace the pump due to leaking seals.

Replacing Pump Seals. After removing the pump from the engine, wipe it carefully to remove all foreign matter. Then, remove the filler cap and drain the pump of all fluid. Remove the reservoir and "O" ring. Use Puller C-3615 to remove the pulley from the shaft.

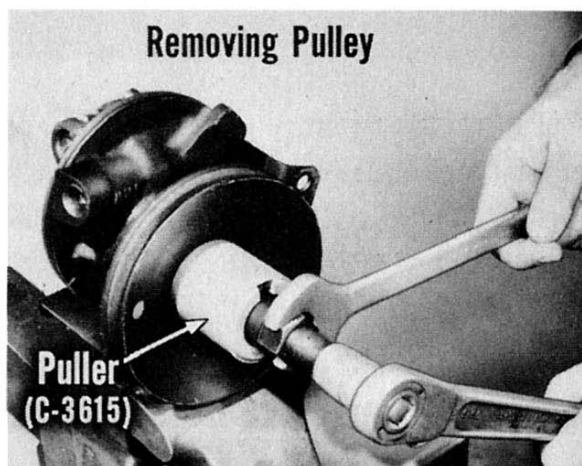

Remove the shaft seal by threading Remover C-3642 into the metal portion of the seal. Then, turn the center screw until the seal is removed.

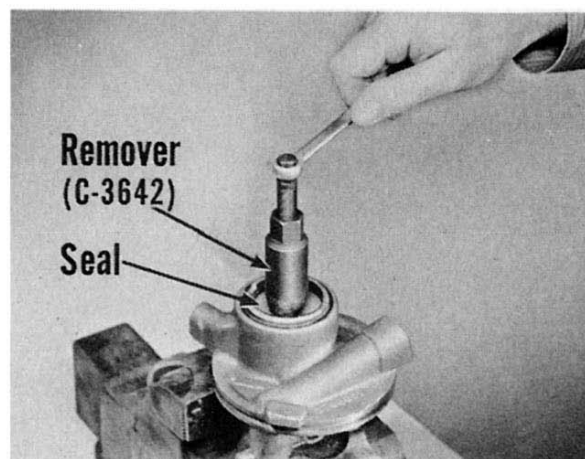

Thoroughly clean the pump shaft and examine the seal contact area of the shaft for score marks or other imperfections that can damage the seal. Minor scratches can be removed with crocus cloth.

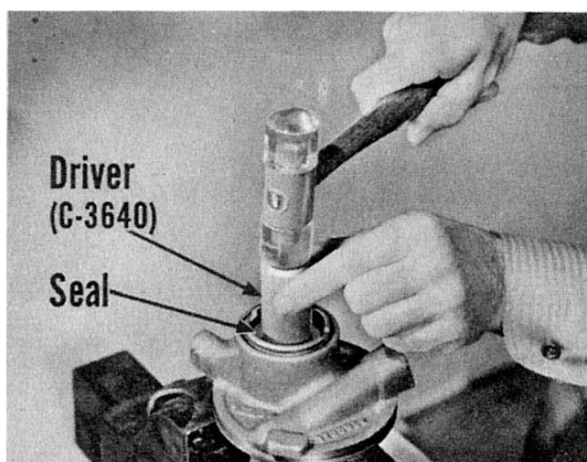

Install the new seal with the lip of the seal toward the pump. Drive the seal in flush, using Driver C-3640.

Place the pump on Stand C-3643 to support the shaft. Then, install the pulley and press it into place on an arbor press. Complete the assembly of the pump by installing a new reservoir seal "O" ring. Carefully examine the edge of the reservoir to be sure it is smooth and even all around.

Lubrication Specifications

Lubrication specifications for the power steering system have been changed. Automatic Transmission Fluid, Type "A", which was formerly specified, should no longer be used.

A new Power Steering Fluid, Part Number 2084329, which is available through your regular parts sources, should be used *exclusively* in all Chrysler Corporation power steering gears. This fluid

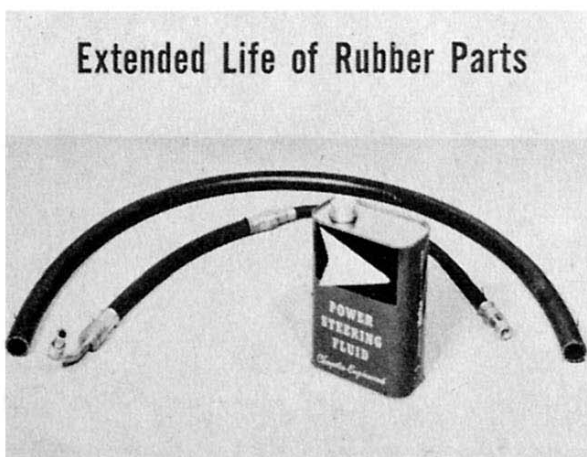

is best suited for these units since it extends the life of all power steering rubber parts, particularly the hoses. This new fluid will mix satisfactorily with the fluid formerly specified. However, when a pump or gear is completely disassembled, refill the system with new Power Steering Fluid.

Diagnosing Power Steering Troubles

When a report is received from a customer that the power steering gear on his car is not functioning properly, the service technician should make every effort to perform a careful, complete diagnosis of the complaint. Failure to perform the diagnosis can often result in the customer being obliged to spend some of his money unnecessarily, when he probably could spend it to better advantage on some other service work he actually needs.

A quick-reference Power Steering Gear Diagnosis Chart is given at the end of this section.

The first step in diagnosing a power steering gear complaint is to examine the fluid level, as outlined earlier. *Always* wipe off the filler neck and cap to prevent foreign matter from dropping into the reservoir when the cap is removed. Foreign matter circulating through the hydraulic system can cause considerable damage to internal parts.



If the fluid level is satisfactory, inspect the pump belt to be sure it is not frayed or otherwise damaged, oily or glazed. If the belt condition is satisfactory, the next step is to see that the belt tension is up to specifications for the model car you are working on. Belt tension can always be set more accurately when a torque wrench is used.

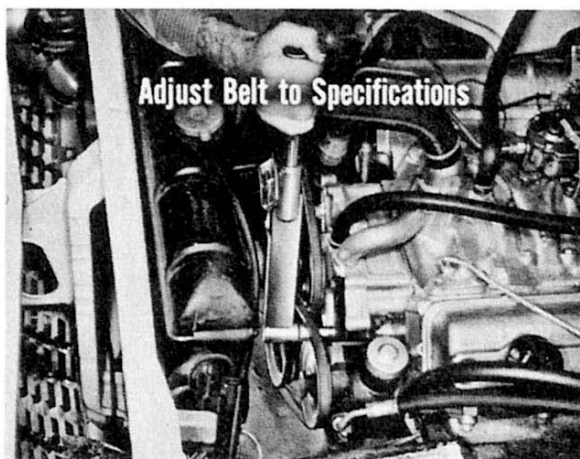

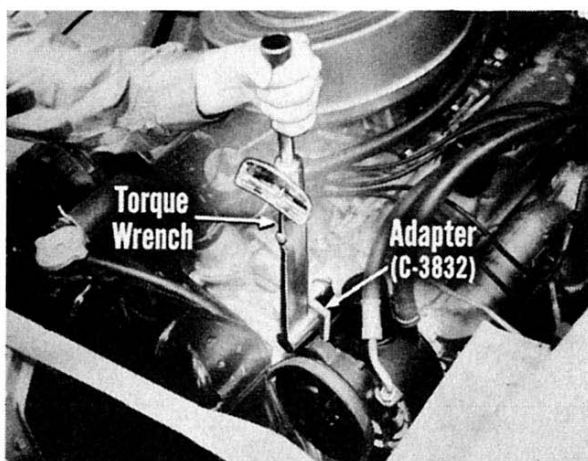

On models using the pump with the automatic belt tensioner, the job can best be done if the torque wrench adapter is used to set up the initial tension of the belt.

Completion of these two steps—fluid level and belt tension—will in many instances correct minor power steering difficulties. If they don't, pressure tests should be made to determine the performance of the pump.

Pressure Tests. It is desirable to make pressure tests of the hydraulic system, particularly if the customer has reported lack of assist. When a technician has a good knowledge of the reasons for low and high pressure readings under certain operating conditions, he can more accurately locate the source of the difficulty.

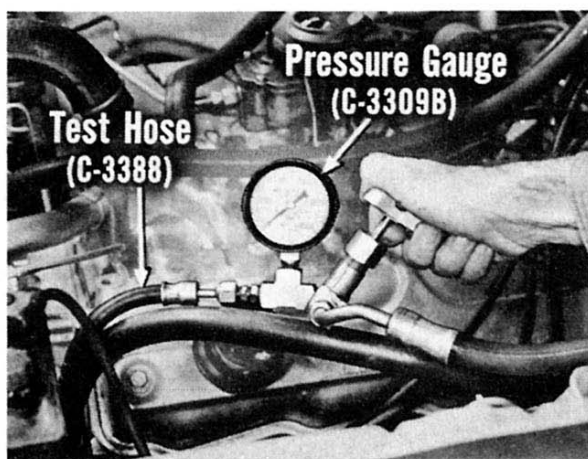

Disconnect the pressure hose at the pump and in its place connect the special test hose (C-3388). Then, connect the shut-off valve and gauge (C-3309B) between the test hose and the pressure hose just disconnected from the pump. Turn the shut-off valve to the *fully-open* position.

Connect a tachometer to the engine. Start the engine, allow it to warm up to normal operating temperature. Set the idle speed at 500 r.p.m. This idle speed applies to all models for this test.

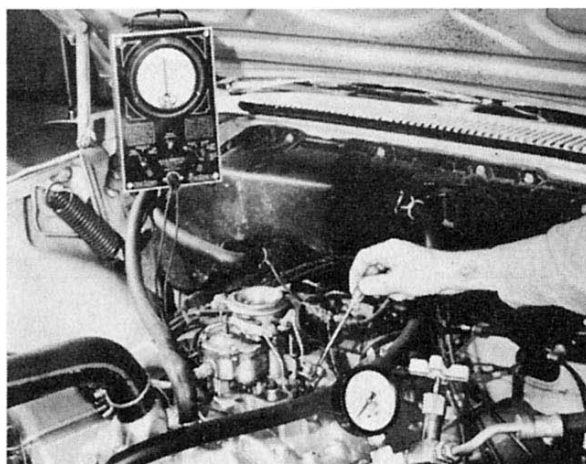

The fluid in the reservoir should reach a temperature of 150° to 170°, as indicated by a thermometer inserted in the pump filler neck, before the test is started.

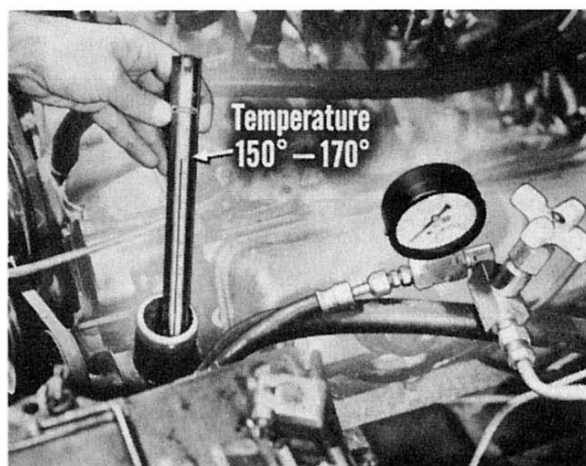

When the fluid reaches the desired temperature, the pressure gauge reading on all Constant-Control power steering units should be fifty-five to eighty pounds per square inch, with the hands removed from the steering wheel. The accompanying Pressure Diagnosis Chart should be used to interpret the reasons for lower than minimum or higher than maximum pressure readings after proper fluid level and belt tension have been established.

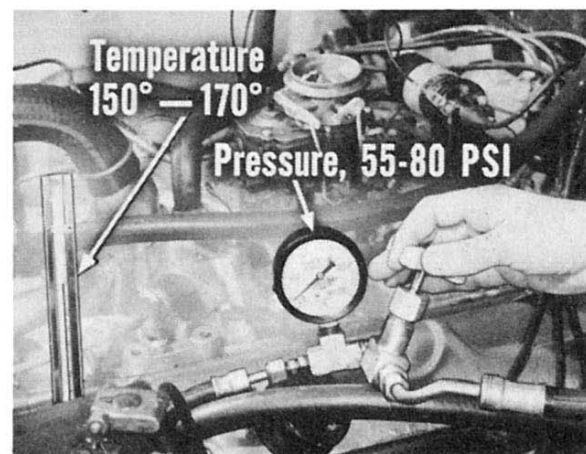

POWER STEERING PUMP PRESSURE DIAGNOSIS CHART

ENGINE PISTON DISPLACEMENT	PRESSURE RANGE		MINIMUM PRESSURE 500 R.P.M. VALVE CLOSED
	500 R.P.M. VALVE OPEN	1000 R.P.M. VALVE CLOSED	
170 CU. IN.	55-80 PSI	650- 750 PSI (a), (b)	650 PSI
225, 313*, 318 CU. IN. (4 ⁵ / ₈ " DIA. PUMP)	55-80 PSI	850- 950 PSI (a), (b)	850 PSI
318 CU. IN. (5 ¹ / ₈ " DIA. PUMP)	55-80 PSI	900-1000 PSI (a), (b)	900 PSI
361, 383 and 413 CU. IN. NEW YORKER	55-80 PSI	1000-1100 PSI (a), (b)	1000 PSI
413 CU. IN. IMPERIAL	55-80 PSI	1150-1300 PSI (a)	1150 PSI
*CANADIAN BUILT	IF PRESSURE IS ABOVE MAXIMUM, IT INDICATES— <ul style="list-style-type: none"> • RESTRICTION IN HOSES • OBSTRUCTION IN HOSE SCREEN • OBSTRUCTION IN GEAR PASSAGES 	IF PRESSURE IS ABOVE MAXIMUM, IT INDICATES— <ul style="list-style-type: none"> (a) FAULTY PRESSURE-RELIEF VALVE (b) WRONG RELIEF VALVE INSTALLED 	IF PRESSURE IS BELOW MINIMUM, IT INDICATES— <ul style="list-style-type: none"> • FAULTY PRESSURE-RELIEF VALVE • FLOW CONTROL VALVE STUCK OPEN • PUMP NOT MEETING SPECIFICATIONS

If the pressure is higher than specified, it indicates there is a restriction in the system. Examine the hoses for kinks and other obstructions, and correct the condition as required.

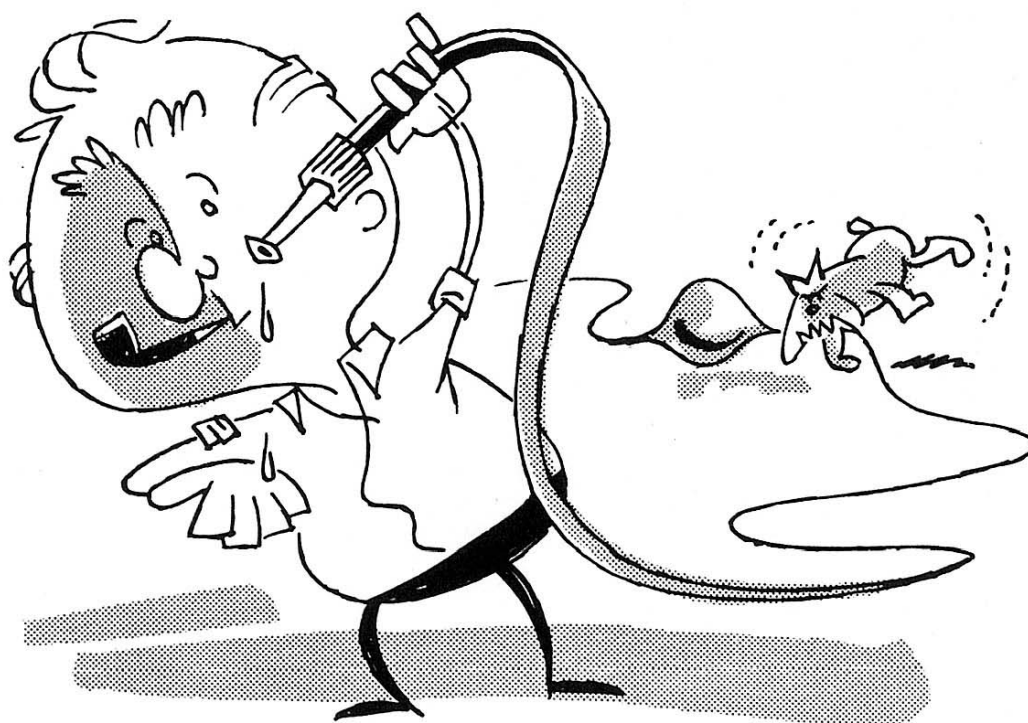
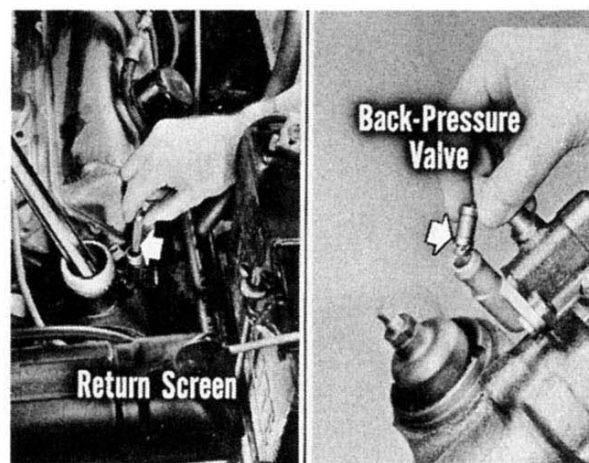

It is also possible there might be an obstruction in the return hose screen at the pump connection. The obstruction might also be in one of the gear passages, or the back-pressure valve in the valve housing might not be working properly.

If further testing is required, increase the engine speed to 1,000 r.p.m., as indicated by the tachometer. Then, slowly close the shut-off valve and note the increase in pressure reading. When the valve

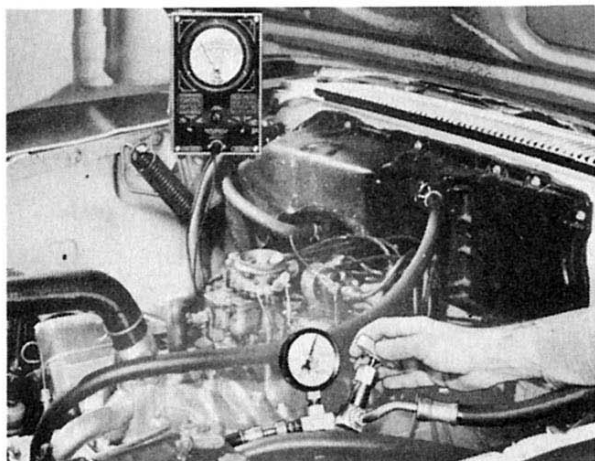

is *fully closed*, the reading should rise to within the range indicated on the Pressure Diagnosis Chart. *Do not hold the valve closed for more than a few seconds when the engine is running, as this will increase the operating temperature of the fluid and pump parts and cause extra pump wear.*

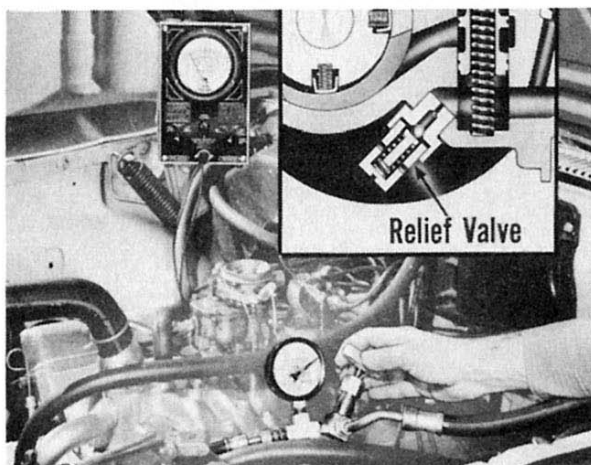

If the pressure rises to more than the maximum indicated on the chart, the relief valve is not opening when it should. It is also possible, in all models except Imperial, that a higher value pressure-relief valve has been installed in the pump.

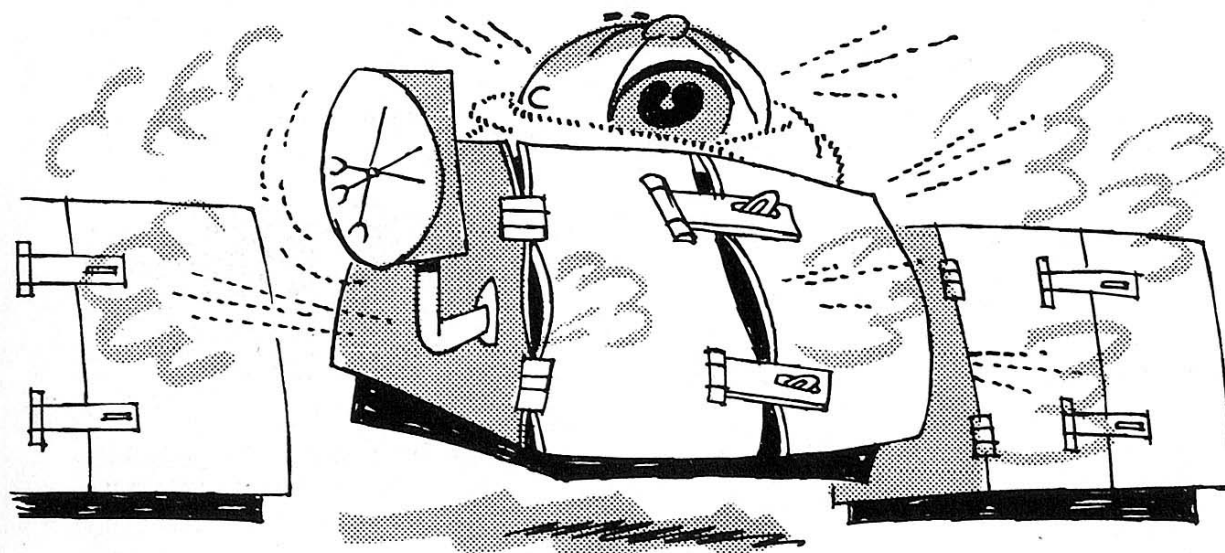

Should the pressure reading be less than the minimum indicated on the chart, the relief valve may be opening too soon. In addition,

the flow control valve may be stuck open, or the pump may not be meeting specifications.

If the pressure readings are satisfactory at 1,000 r.p.m., drop the engine speed to 500 r.p.m. Then, *momentarily close* the shut-off valve. The pressure reading should remain about the same as at 1,000 r.p.m. If there is a difference in the readings, inspect the flow control valve for freedom of operation. Also, inspect the relief valve installation for proper sealing with its gasket.

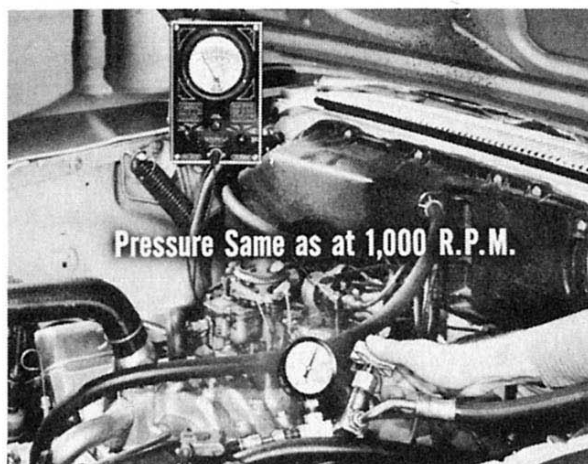

If these valves are satisfactory, the trouble is probably due to internal wear, and the pump replacement package should be used. Remove the pulley from the old pump, as previously described, for installation on the new pump. Also, remove the reservoir and pressure-relief valve and install them on the new pump. When installing the relief valve, be sure to use a new gasket and tighten the valve body securely in the pump body. Also, be sure to install the new reservoir gasket and "O"-ring supplied in the pump package.

If the tests indicate the pump to be operating satisfactorily, one more pressure test should be made to test the gear. With the engine running at 1,000 r.p.m. and with the shut-off valve *open*, have a helper turn the steering wheel from one extreme to the other, holding the wheel momentarily when it

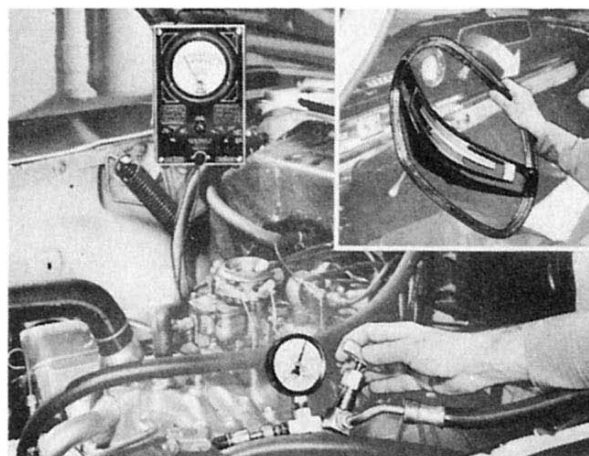

reaches the end of the turn. The gauge readings at each extreme should be the same, and within the range of the relief valve. If the readings are different, it indicates internal leakage in the gear unit, or an improperly operating spool valve.

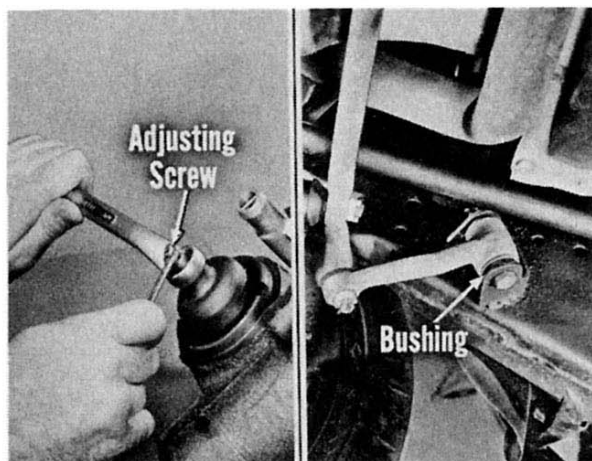

Sticky Steering and Wandering. If a customer reports sticky steering, wandering, or lack of returnability, it is possible the difficulty could be due to a tight cross shaft adjustment or a worn idler arm bushing. These two possibilities should be explored and corrections made, if necessary.

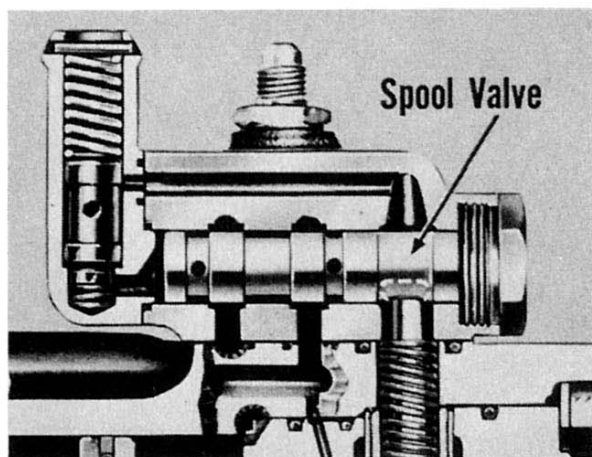
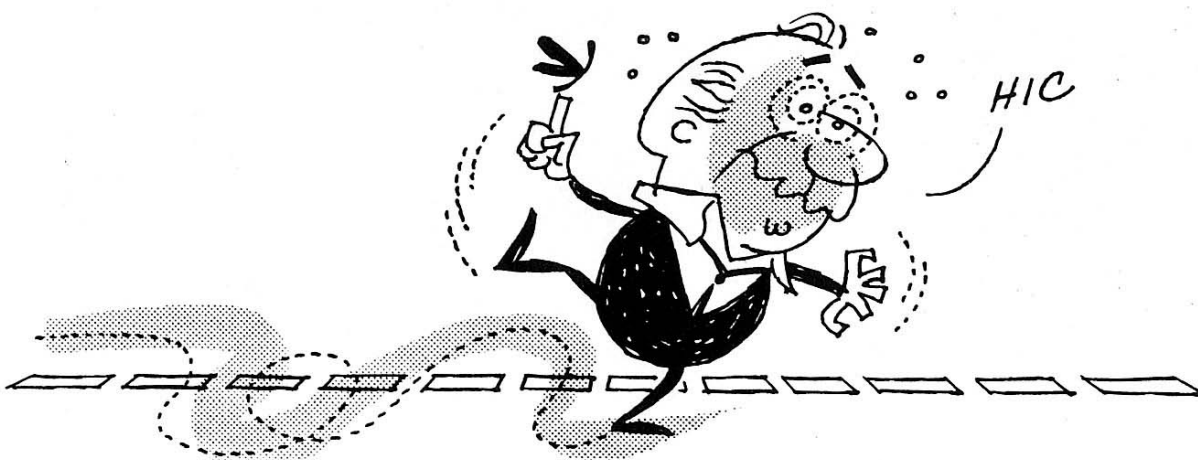

If an examination of these two areas indicates no difficulties, there is a likelihood that the trouble is due to the spool valve in the valve housing on the steering gear not operating freely.

To determine the condition of the valve, remove the valve housing assembly from the gear. Disassemble it, and clean all parts in solvent and dry them with compressed air. Place the spool valve in the housing and install the end plug. Test the movement of the valve in the housing bore by inverting the housing several times. If the valve moves freely from one end of the bore to the other of its own weight, it can be assumed the valve functions satisfactorily.

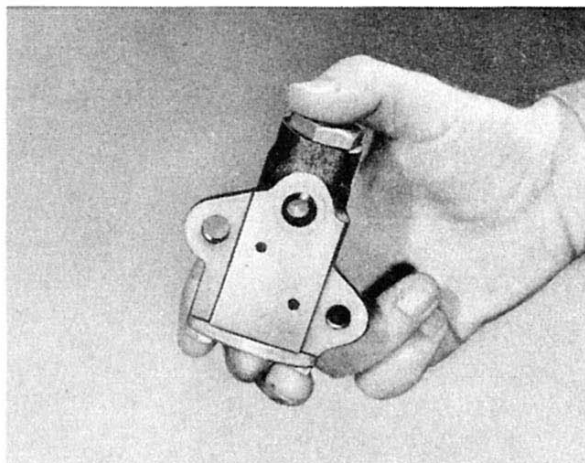

If the spool valve sticks in the housing bore, remove and examine the valve and bore for nicks, burrs and score marks.

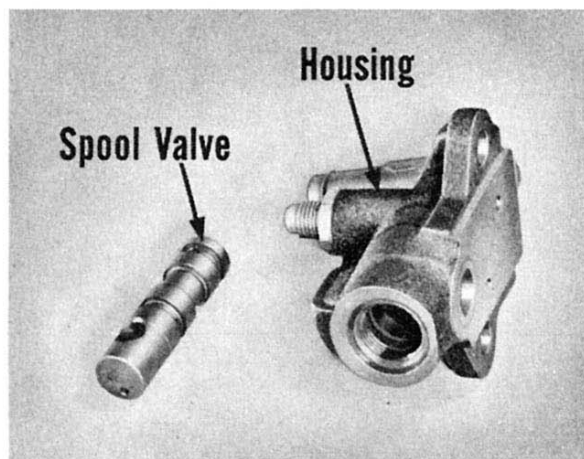

Minor imperfections, if found on the valve and in the bore, can usually be removed by polishing with crocus cloth. Be careful not to round off the edges on the spool or bore. If the valve is too badly damaged, replace the valve *and* the housing, since these parts are supplied as a fitted assembly.

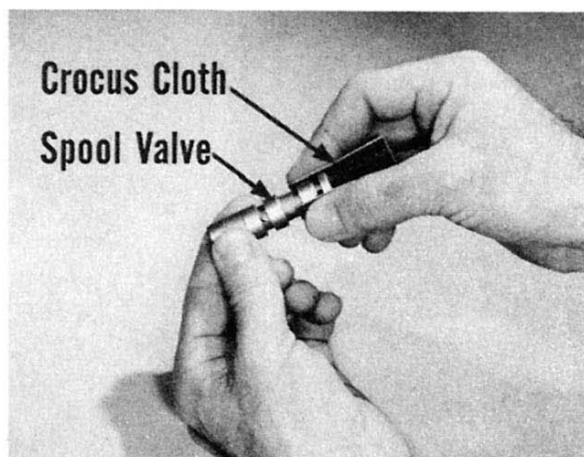

Also, carefully examine the back-pressure valve and its two springs to be sure they are in satisfactory condition. Broken or weak springs should be replaced. When reassembling the housing, be sure to use new "O" rings and gaskets.

If, after the above steps have been taken and no improvement is noted in the operation of the gear, there is only one course open and that is to remove the gear assembly from the car, disassemble it, clean and examine the individual parts and make such corrections and replacements as are necessary to obtain satisfactory service from the unit.

Oil Leak—Cross Shaft Oil Seal Snap Ring. There have been occasional reports of an oil leak at the lower end of the steering gear cross shaft on models equipped with power steering. When investigating a report of this nature, carefully note the position of the oil seal snap ring. If the ring is not properly in place in its groove in the gear housing, it is likely the ring was installed with the side with the sharp edge facing *inward* instead of *outward*. When installed in this manner, the ring may snap out of the groove.

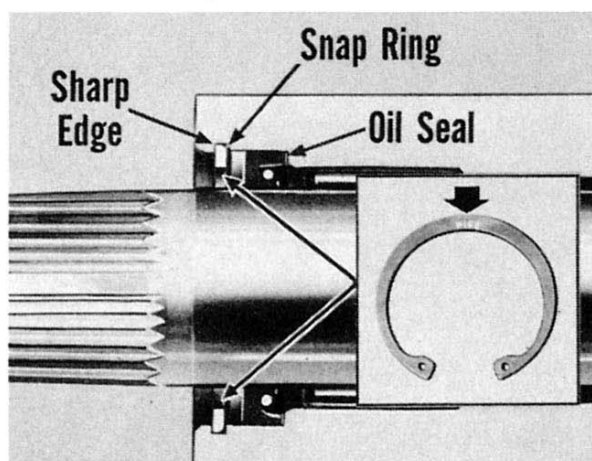

To provide a better seal at this point, on cars other than Valiant and Lancer, a new improved snap ring was recently released for use in both production and service. It is identified by the number W-168, stamped on the side with the *sharp* edge.

This new ring should be used exclusively in service, whenever there is an occasion to disassemble the steering gear or replace the cross shaft oil seal on all cars except Valiant and Lancer. When installing the ring, be sure the side with the number and sharp edge

is facing *outward*, toward the steering arm. In this way the ring will seat firmly in its groove and there is no possibility of it popping out and causing an oil leak.

Do not reinstall the old snap ring. Always use a new one, and be sure the side with the sharp edge is facing outward.

Chuckling Noise. There may be reports of a chuckling noise in the steering gear of a car equipped with power steering, when driving over railroad tracks or rough roads. The first item to examine would be the cross shaft adjustment. If the adjustment is satisfactory, or an adjustment does not afford relief, it is possible there is looseness in the steering gear coupling.



Looseness at this point can be determined by rocking the steering wheel and shaft in the housing. If there appears to be excessive movement, it is possible the rubber insulator and the plastic inserts in the insulator are damaged, or the insulator is undersize.

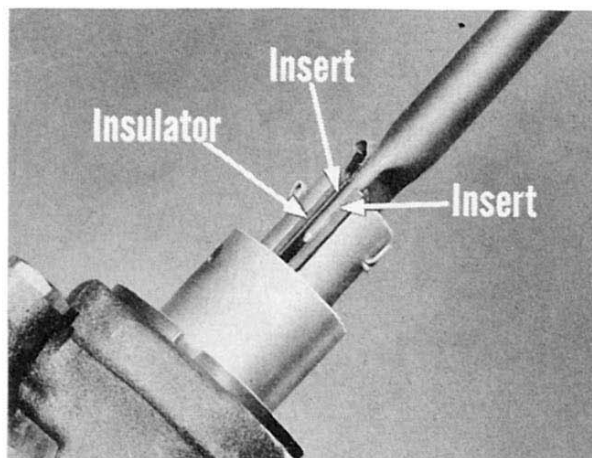

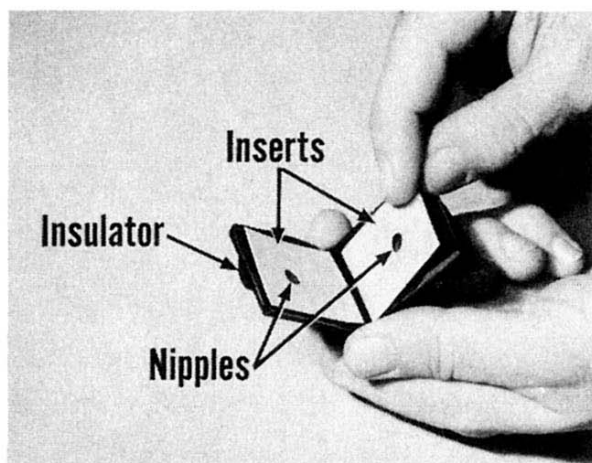

To correct this condition, remove the steering gear shaft and coupling from the gear. When installing new parts, be sure one insert is assembled on each side of the rubber insulator, and that the nipples on the insulator pass through the holes in the inserts to hold them in position in the insulator.



When these parts are assembled on the blade end of the steering tube, about three-to-fifteen pounds pressure should be required to push the parts into the coupling.

If less than the specified pressure is required to assemble the shaft in the coupling, the insulator might be slightly undersize. In that case, add another insert to one side. This will usually provide the proper thickness of the assembly to prevent looseness at this point.

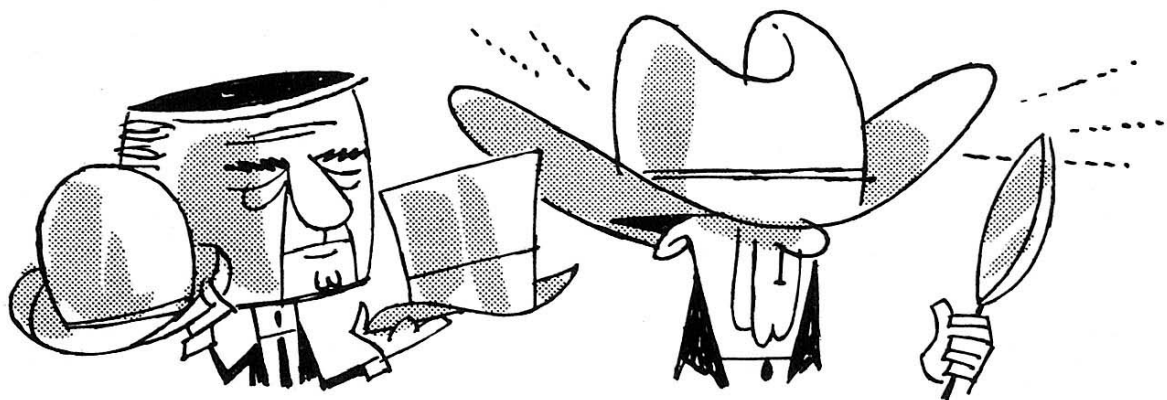

POWER STEERING DIAGNOSIS CHART

DIFFICULTY	PROBABLE CAUSE (see Key at right)	KEY TO PROBABLE CAUSE
Hard steering	(a), (b), (d)	(a) Low fluid level (pump)
Poor recovery on turns	(c), (e), (f), (g)	(b) Loose pump belt (high-pitch squeal)
Self-steering or leads to either side	(c), (e), (h)	(c) Low or uneven tire pressure
Intermittent power assist	(a), (b), (d), (g), (i)	(d) Glazed pump belt (high-pitch squeal)
Lack of power on turns	(a), (b), (d)	(e) Improper front-end alignment
Gear chuckle	(f), (g), (j)	(f) Gear shaft adjustment
Excessive free play in steering	(f), (g)	(g) Steering linkage binding or worn
		(h) Valve body out of adjustment
		(i) Engine idle too low
		(j) Looseness at steering gear coupling

MANUAL STEERING

Hard Steering and Wandering— Valiant and Lancer

A customer may report that more than the normal amount of effort is required to steer the car, and that it has a tendency to wander.

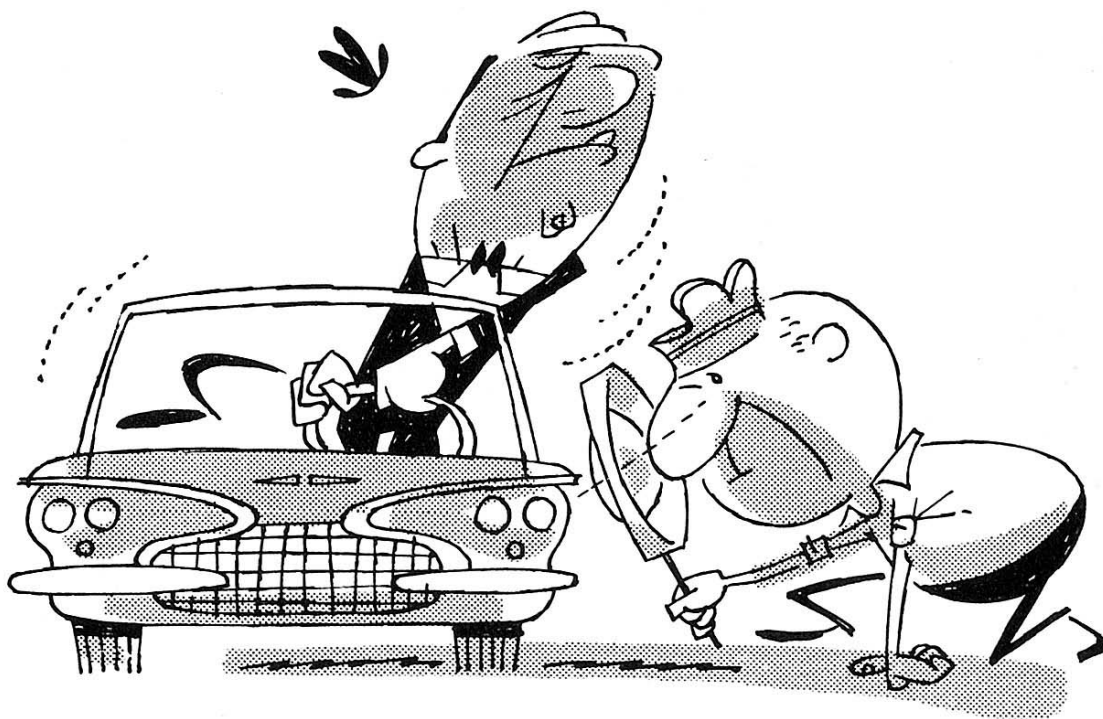

Examine the tires for uneven and low tire pressure; inspect the steering gear housing and linkage for lack of lubrication; test for improper front-end alignment and improper cross shaft adjustment. It should be remembered that the correct cross shaft adjustment is just as important on manual steering gears as it is on power steering units. These are the most common causes of this type of complaint.

If after examining these points, the difficulty still exists, the torque required to turn the steering shaft should be tested. To do this, disconnect the steering linkage at the steering arm. Then, back off the cross shaft adjustment two turns of the adjusting screw. Next, remove the horn ring and turn the steering wheel exactly two complete turns from the straight-ahead position.

Place Torque Wrench C-3380 with Adapter C-3790 on the steering shaft nut. Rotate the steering wheel at least one complete turn toward the straight-ahead position. The torque required to keep the shaft moving should be between two and five inch-pounds. If the reading is not within these specifications, the worm bearing pre-load should be re-adjusted.

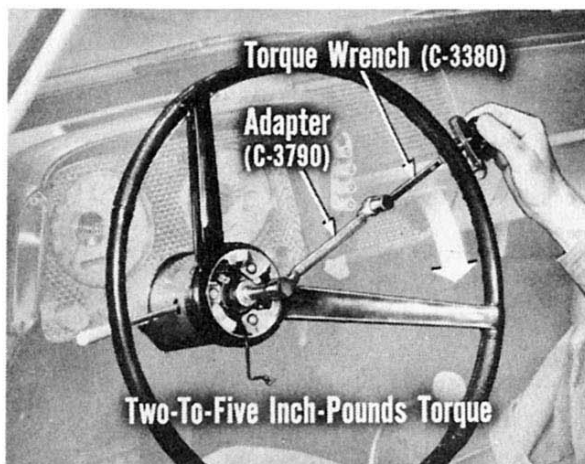

To adjust the pre-load, first loosen the adjuster locknut. Then, turn the adjuster counterclockwise to decrease the pre-load, or clockwise to increase the pre-load. When the desired torque is obtained, tighten the locknut securely.

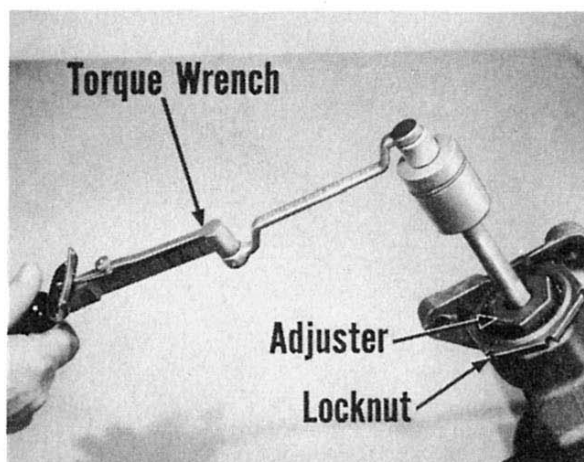

FRONT SUSPENSION

Ball Joints – Valiant and Lancer

Road dirt thrown up on the ball joints from wet road surfaces or from dusty gravel roads can shorten the life of the joints if they are not properly protected. When work is being done on front suspension parts, careful attention should be given to the condition of the ball joint rubber seals. If they show signs of deterioration, are torn or otherwise are not in satisfactory condition, the installation of new seals will help save the customer the expense of costly repairs later.

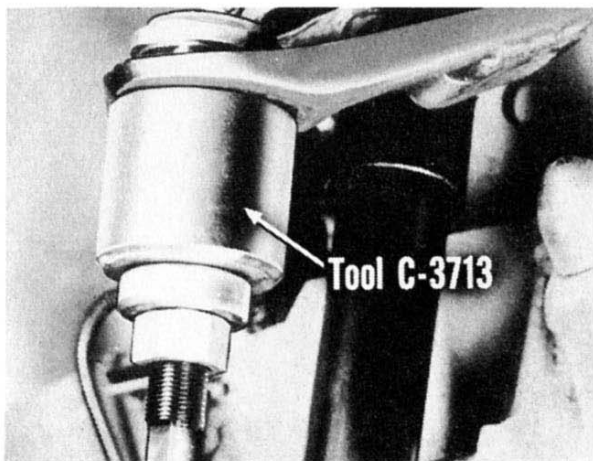
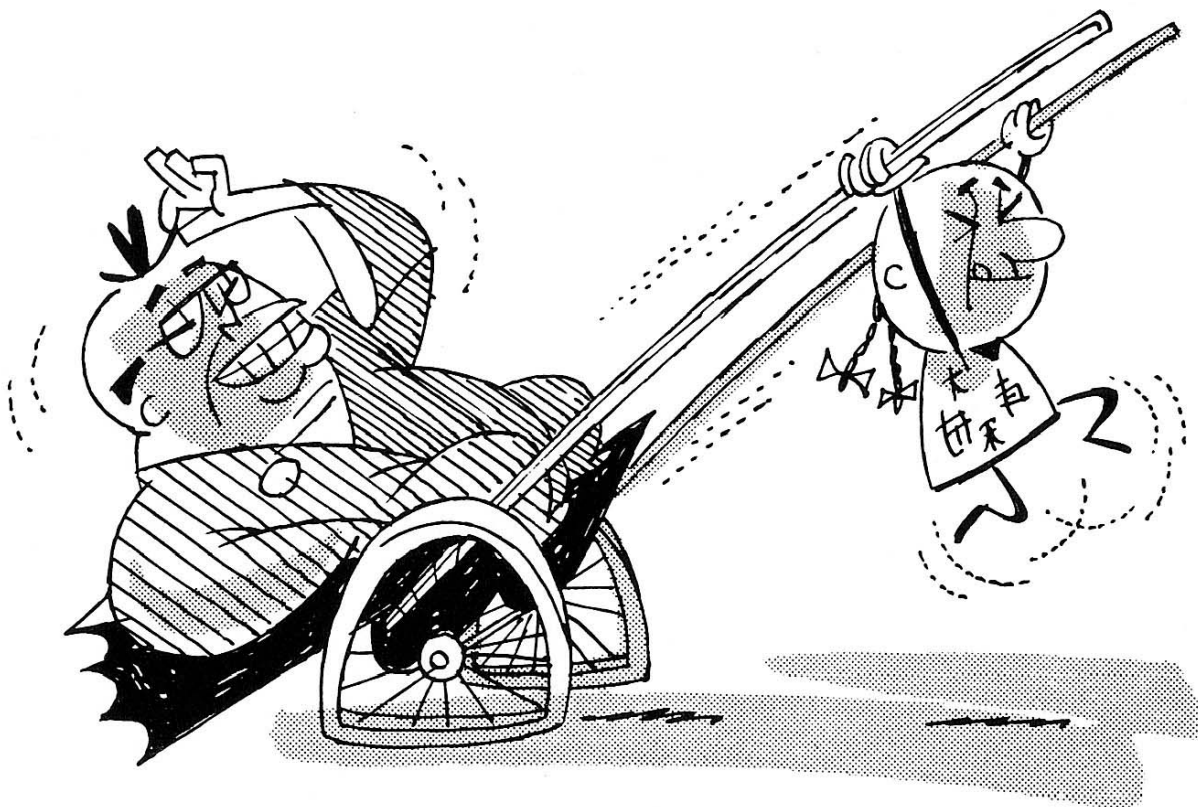

When installing new seals, be careful to avoid tearing the seal and damaging the metal retainer. Always use the Seal Installer C-3713 to assure doing a good job.

Torsion Bars – Valiant and Lancer

If, for any reason, it is necessary to remove one or both torsion bars on these models, every precaution must be exercised to avoid scoring the surfaces of the bars. The bars can be easily removed by using Torsion Bar Removing Tool C-3728.

To remove the bar, place the two halves of the tool on the bar,

close to the front end of the bar, with the half provided with the striking pad on the bottom. Tighten the four socket-head-type screws evenly and securely to prevent the tool from slipping and scoring the bar. Hit the striking pad on the tool several sharp blows to loosen the bar from its anchors.



If, in the course of removing or handling the bar, its surface should become scored, use crocus cloth to polish the affected area. Then, paint it with a rust-preventive paint to guard against corrosive action.

When installing the bar, the balloon-type seal must be placed on the bar with the cupped side to the rear. Coat both ends of the bar with multi-purpose grease.



In addition, the annular opening in the rear anchor must be packed with the same type of grease before the lip of the seal is engaged in the groove in the anchor.

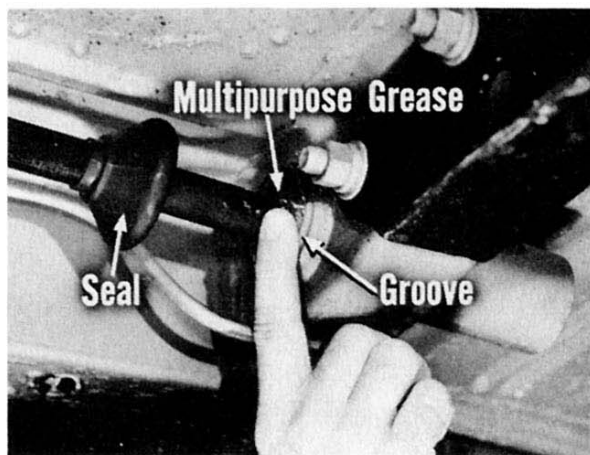

The use of the multi-purpose grease in the anchor and on the ends of the bar will prevent road dirt and salt from entering the anchor, and will guard against the accumulation of rust and corrosion.

Torsion Bars—All Models

When there is a need to install new torsion bars, always use Chrysler Corporation pre-stressed bars. These bars are manufactured to high standards to provide maximum life and satisfactory service. The bars are not interchangeable from side to side. They are stressed

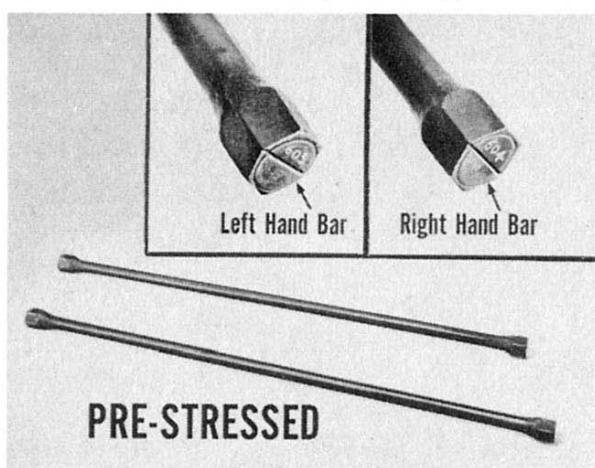

for right and left side use. Each bar is stamped on the anchor end with a three-digit number. If the last digit is an *odd* number, the bar is for *left side* installation. Bars with the last digit an *even* number indicates the bar is for *right side* installation.

Front-End Alignment

The front-end specifications on all models remain the same, with the exception of camber, which has been increased one-eighth degree over the preceding models.

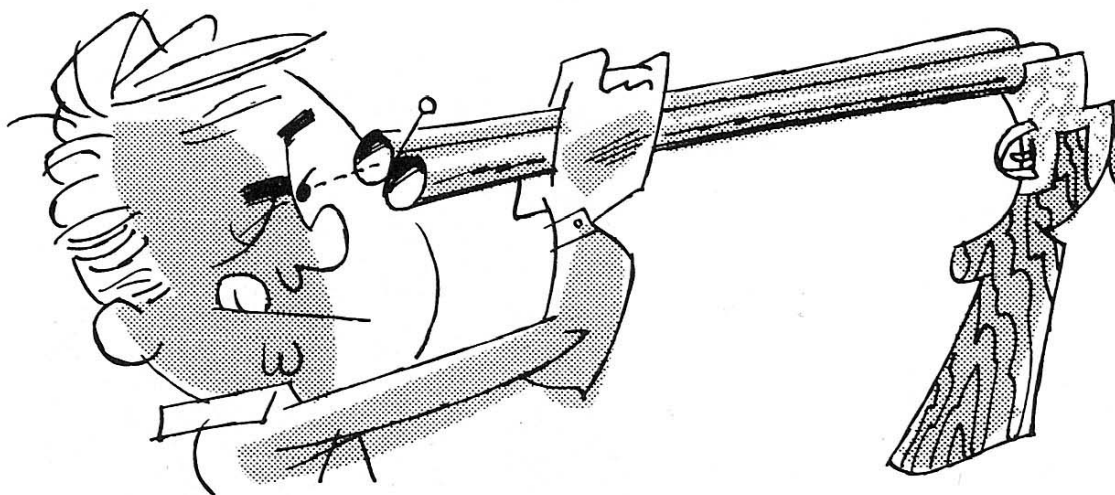

It is important to remember that car front height must be correct before adjusting caster and camber. If the car front height is not adjusted to specifications, it will be impossible to obtain proper caster and camber readings.

Car Height—Valiant and Lancer

When correcting car front height on Valiant and Lancer models, always work toward the maximum rather than the minimum tolerance. The specifications for these models call for one-and-three-quarters inches, plus or minus one-eighth inch. A reading of one-and-seven-eighths is preferred to a reading one-and-five-eighths inches.

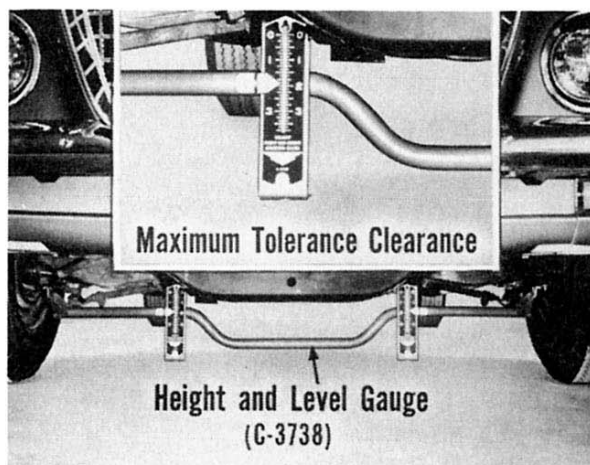

Rubber Bushings

Rubber bushings are used in numerous locations in the front suspension system to absorb road shock. Deterioration or damage to these bushings due to the application of oil or other fluids, and loose connections due to improperly tightened nuts can result in difficulty in maintaining proper front-end alignment. In addition, looseness of the nut on the front end of the strut can also cause brakes to pull the car to one side on brake application.

When preparing to align the front end, it is advisable to first examine the cam adjusting rubber bushings, the lower control arm shaft bushings and, in particular, the lower control arm strut bushings. Any bushing found to be in unsatisfactory condition should be replaced before proceeding with the alignment procedure.

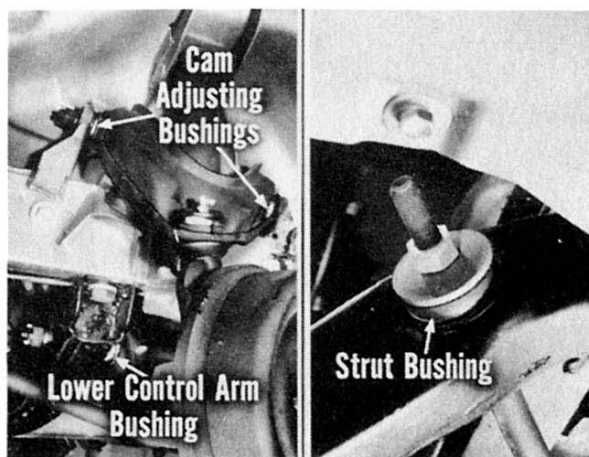

Rear Shock Absorbers—Plymouth, Dodge, De Soto and Chrysler

On some early production models, the customer might report a noisy rear shock absorber condition. Investigation has disclosed that the noise, while appearing to originate in the shock absorbers, is actually in the upper mounting. Interference between the shoulder on the mounting stud and the body sheet metal prevents proper tightening of the stud nut.

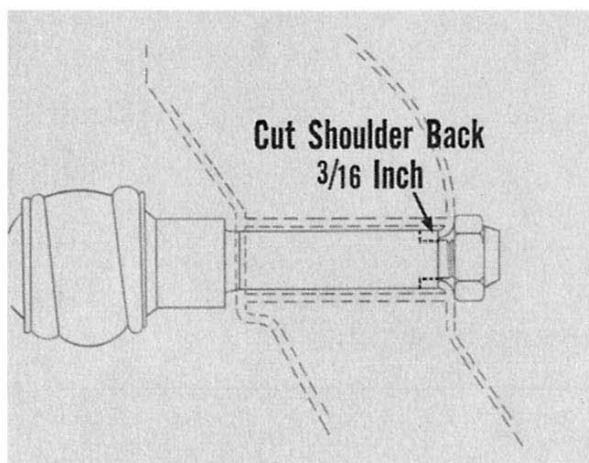

The interference can be eliminated by removing the stud and reducing the length of the shoulder $\frac{3}{16}$ of an inch. This will permit the stud to be drawn up until it seats against the mounting bracket.

NEW-CAR STEERING INSPECTION PROCEDURE

One of the most important operations a dealer can perform for his customers, when preparing the new car for delivery or at the 1,000-mile or 2,000-mile inspection periods, is the inspection, adjustment and tightening of the steering and front suspension systems. When this service is properly performed it will assure the customer complete satisfaction in the handling of the new car.

Particular attention should be given to the inspection and tightening of all mounting bolts and clamps.

The procedure includes the following:

1. Examine the power steering pump fluid level on cars equipped with power steering. If the level is low, add sufficient Power Steering Fluid to bring the level up to requirements.
2. Examine the power steering hose connections and drive belts on cars equipped with power steering, and tighten them to proper specifications. Also, tighten power steering pump mounting bolts securely.
3. Examine the lubricant level in the steering gear housing on cars equipped with manual steering. Add lubricant, if needed, sufficient to cover the gears.
4. Tighten the steering gear and bracket mounting bolts to proper torque specifications.
5. Adjust the front wheel bearings.
6. Inspect the steering arms, idler arm, center link, tie rods and lateral struts to be sure they are properly secured.
7. Examine front-wheel toe-in, and adjust if necessary. Tighten the tie rod adjusting tube clamp bolt nuts to proper torque specifications.
8. Road-test the car to determine its steering qualities and roadability.

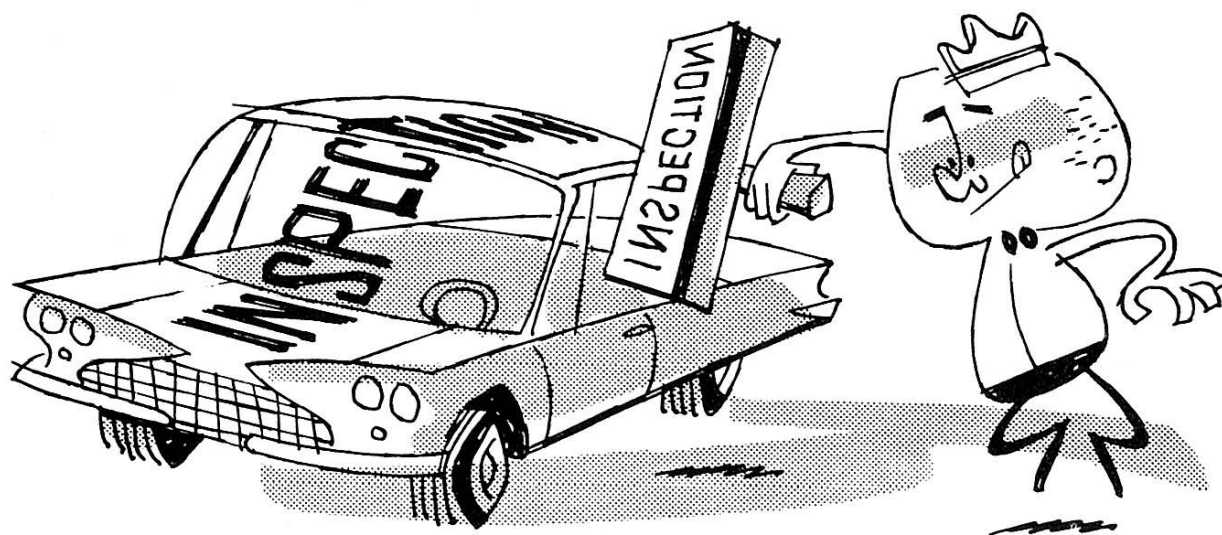

CONCLUSION

The customer's safety on the road is every Master Technician's main concern. How well the car handles in all types of traffic conditions is evidence to the customer of how well you have diagnosed and corrected any problems which he may have reported.

By giving careful attention to his needs you can build up his confidence in your skill as a technician. This will spread your reputation, and will be an important factor in selling him a new car year after year.

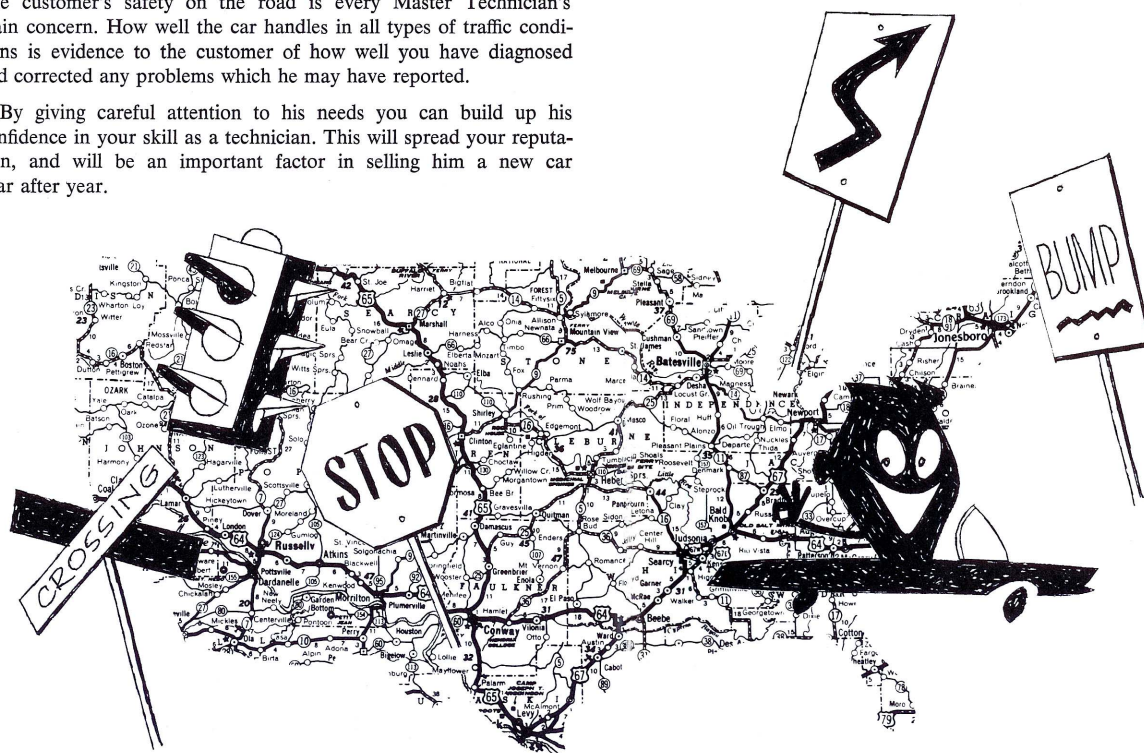

CONCLUSION

The customer's safety on the road is every Master Technician's main concern. How well the car handles in all types of traffic conditions is evidence to the customer of how well you have diagnosed and corrected any problems which he may have reported.

By giving careful attention to his needs you can build up his confidence in your skill as a technician. This will spread your reputation, and will be an important factor in selling him a new car year after year.

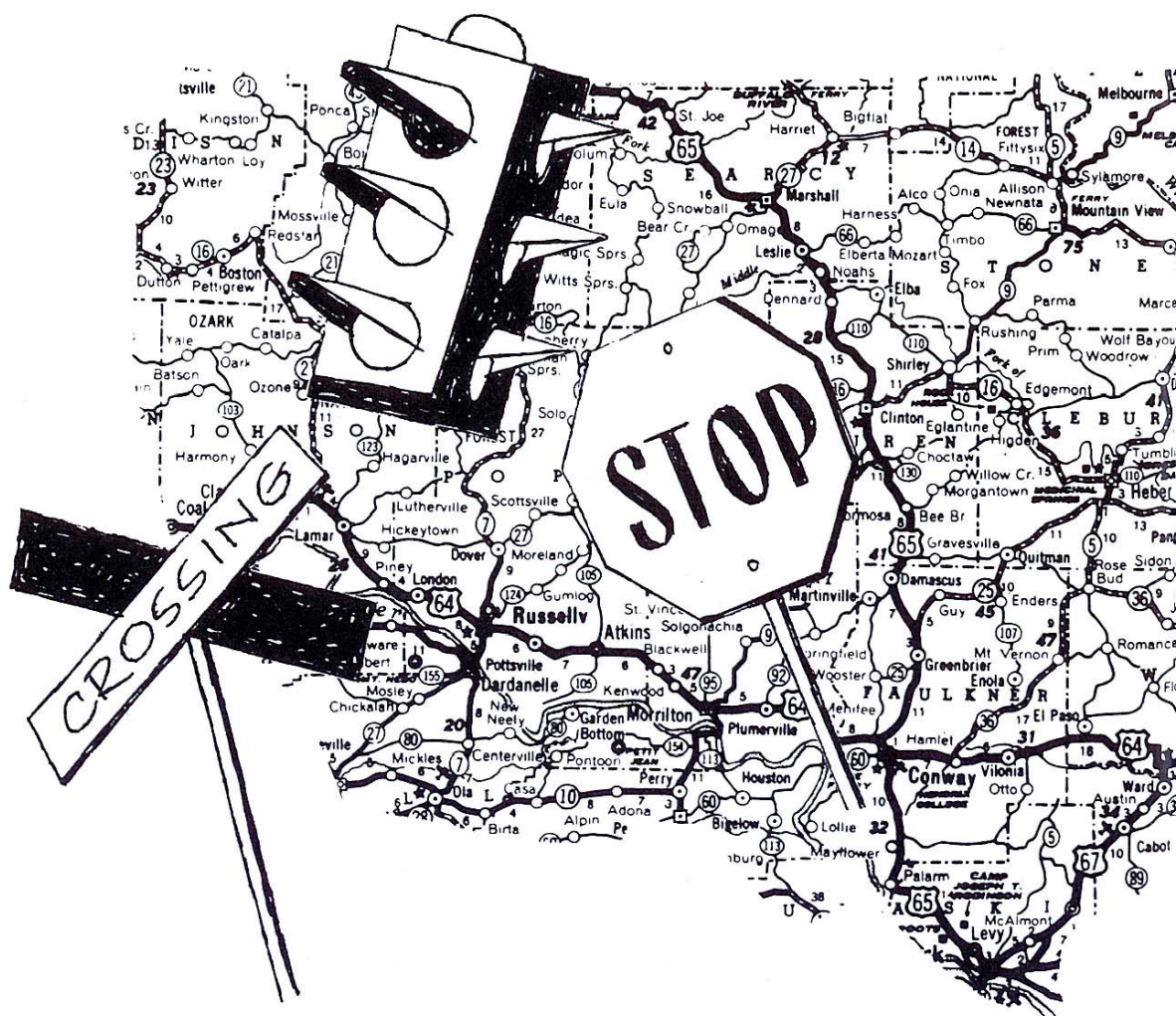

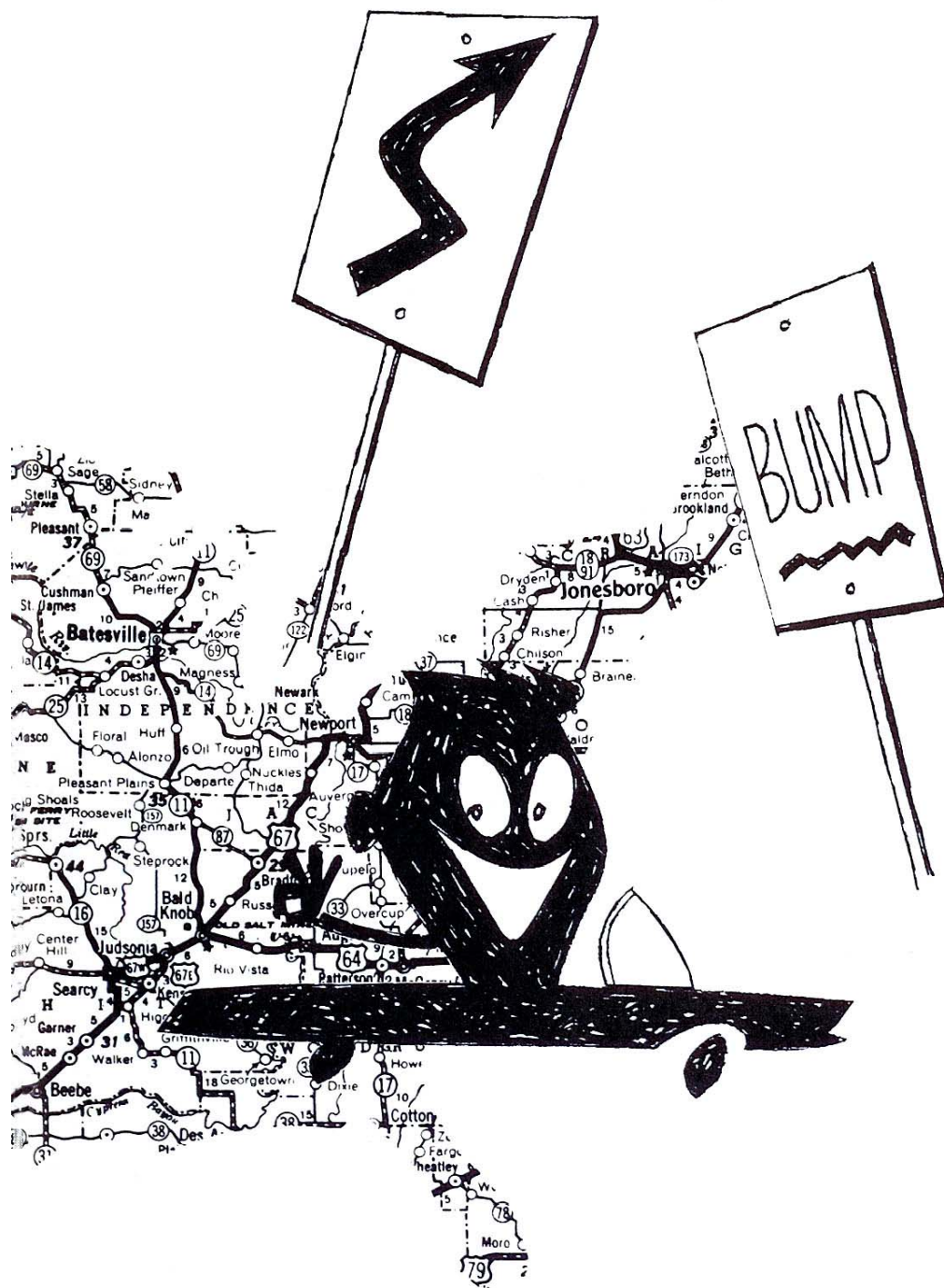

RECORD YOUR ANSWERS TO THESE QUESTIONS ON QUESTIONNAIRE NO. 159

- | | | | |
|---|--------------------------------|-----------|--------------------------------|
| If a car equipped with power steering is steered when the engine is not running, fluid is not being circulated and the piston may force the fluid up into the reservoir and out through the vent in the filler cap. | <input type="radio"/>
RIGHT | 1 | <input type="radio"/>
WRONG |
| When adding fluid to the power steering system, bring the level up to the bottom of the filler neck if the fluid is warm, or halfway up the neck if the fluid is cold. | <input type="radio"/>
RIGHT | 2 | <input type="radio"/>
WRONG |
| Replacement of the pump shaft seal and reservoir "O" ring cannot be made separately—the complete pump would have to be replaced. | <input type="radio"/>
RIGHT | 3 | <input type="radio"/>
WRONG |
| Holding the shut-off valve closed for more than a few seconds when the engine is running will not affect the operating temperature of the fluid and pump parts. | <input type="radio"/>
RIGHT | 4 | <input type="radio"/>
WRONG |
| If either the spool valve or the valve housing is badly damaged, both parts must be replaced with a fitted assembly. | <input type="radio"/>
RIGHT | 5 | <input type="radio"/>
WRONG |
| Looseness in the coupling in power steering gears could be due to a damaged insulator and insulator inserts, or to an undersized insulator. | <input type="radio"/>
RIGHT | 6 | <input type="radio"/>
WRONG |
| Torsion bars on Valiant and Lancer models can be easily removed by using Tool C-3728. | <input type="radio"/>
RIGHT | 7 | <input type="radio"/>
WRONG |
| When installing torsion bars, pack the anchor with multi-purpose grease to guard against rust and corrosion. | <input type="radio"/>
RIGHT | 8 | <input type="radio"/>
WRONG |
| Chrysler Corporation approved torsion bars are interchangeable, side to side. | <input type="radio"/>
RIGHT | 9 | <input type="radio"/>
WRONG |
| Deteriorated or damaged front suspension rubber bushings will have no effect on gauge readings when aligning the front end. | <input type="radio"/>
RIGHT | 10 | <input type="radio"/>
WRONG |