

SERVICE REFERENCE BOOK

SESSION NO.

112

SERVICE TIPS:
SLEEVE-TYPE POWER STEERING PUMP
AND TOTAL-CONTACT BRAKES

Prepared by **CHRYSLER CORPORATION**

Plymouth • Dodge • De Soto • Chrysler and Imperial Divisions

**Tech
sez:**

“STEERING AND BRAKES ARE VITAL CAR CONTROLS”

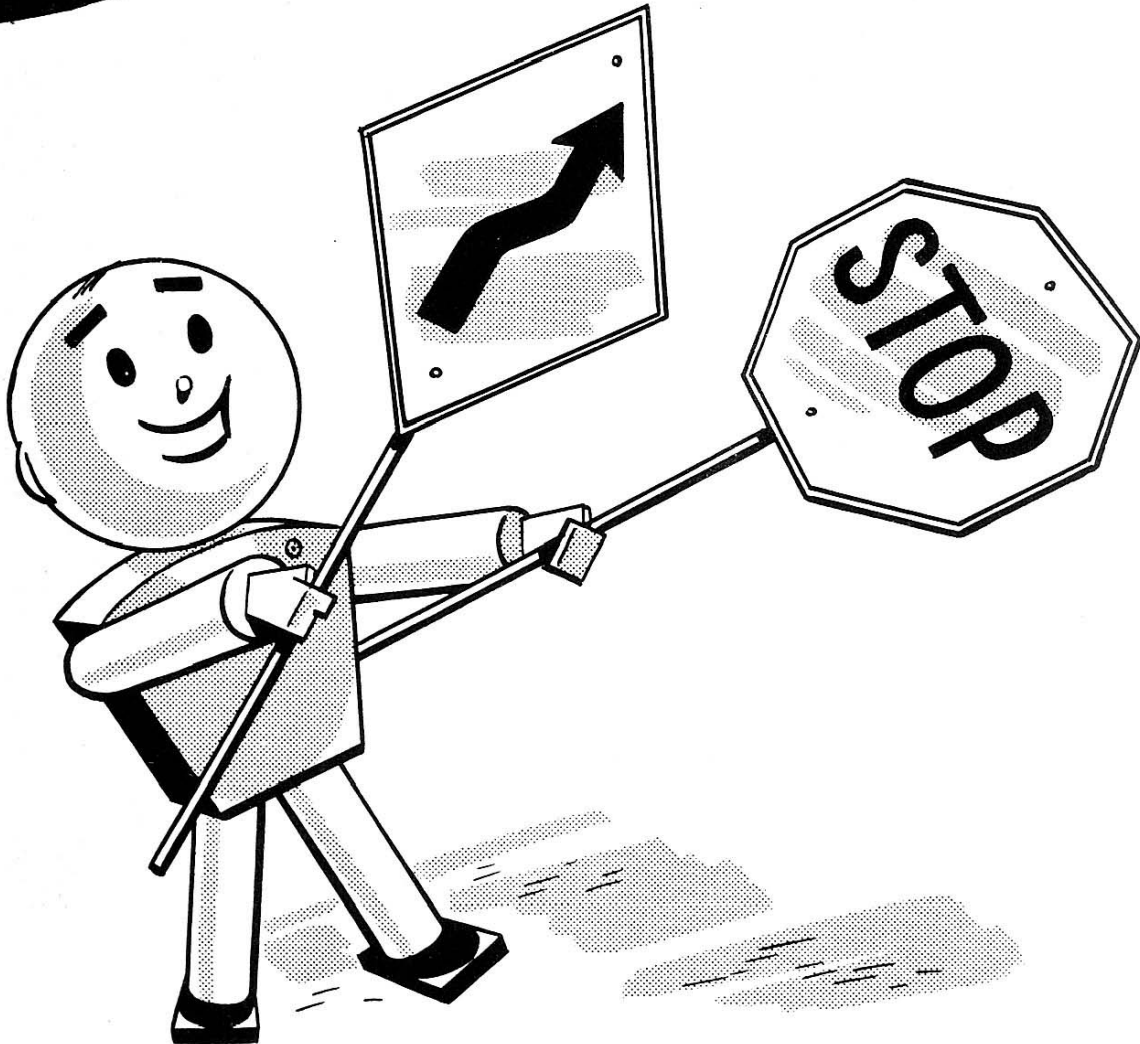

You don't need Tech to tell you that a driver's safety depends a lot on how well his car steers and stops. Steering and brakes have always been two of the most vital car controls. That's nothing new to most of you. Keeping cars safe has always taken top priority with Master Technicians.

That's why it's smart for all of us to brush up on the service procedures which apply to the newest type of power steering and total-contact brakes.

This reference book brings you the latest information available on sleeve-type power steering pump performance, and how to keep our Total-Contact brakes at their best.

Here's where you'll find these useful service suggestions:

	<i>Page No.</i>
HOW THE SLEEVE-TYPE PUMP WORKS	3
SOME PUMP CONDITIONS TO CHECK	8
LUMPY, HARD STEERING—ON-OFF POWER ASSIST	10
HOW TO INSPECT THE FLOW VALVE	12
HOW TO REASSEMBLE THE PUMP	16
OTHER PUMP CONDITIONS	19
LOOSE PUMP PULLEY	19
INNER RACE BEARING FAILURE	20
TIPS ON SERVICING THE TOTAL-CONTACT BRAKES	20
BRAKE NOISE	22
GLAZED DEPOSITS	24
GRABBY, ERRATIC BRAKES	25
BRAKE ADJUSTMENT	25
SUMMARY	26

HOW THE SLEEVE-TYPE PUMP WORKS

As a reminder, let's review the importance and place of the pump in the power steering system. Basically, a power steering system consists of three main elements: the pump; the control valve; and the steering gear assembly with its power piston. The pump gets its power from the engine and converts it into usable energy for the steering system.

The control valve regulates and routes the energy in the proper direction. The power piston takes this directed energy and uses it to help the driver steer the car. As you can see, the power steering pump must supply enough oil at proper pressures to meet the slightest or most extreme demands in an effort to assist the driver.

SLEEVE-TYPE POWER STEERING PUMP

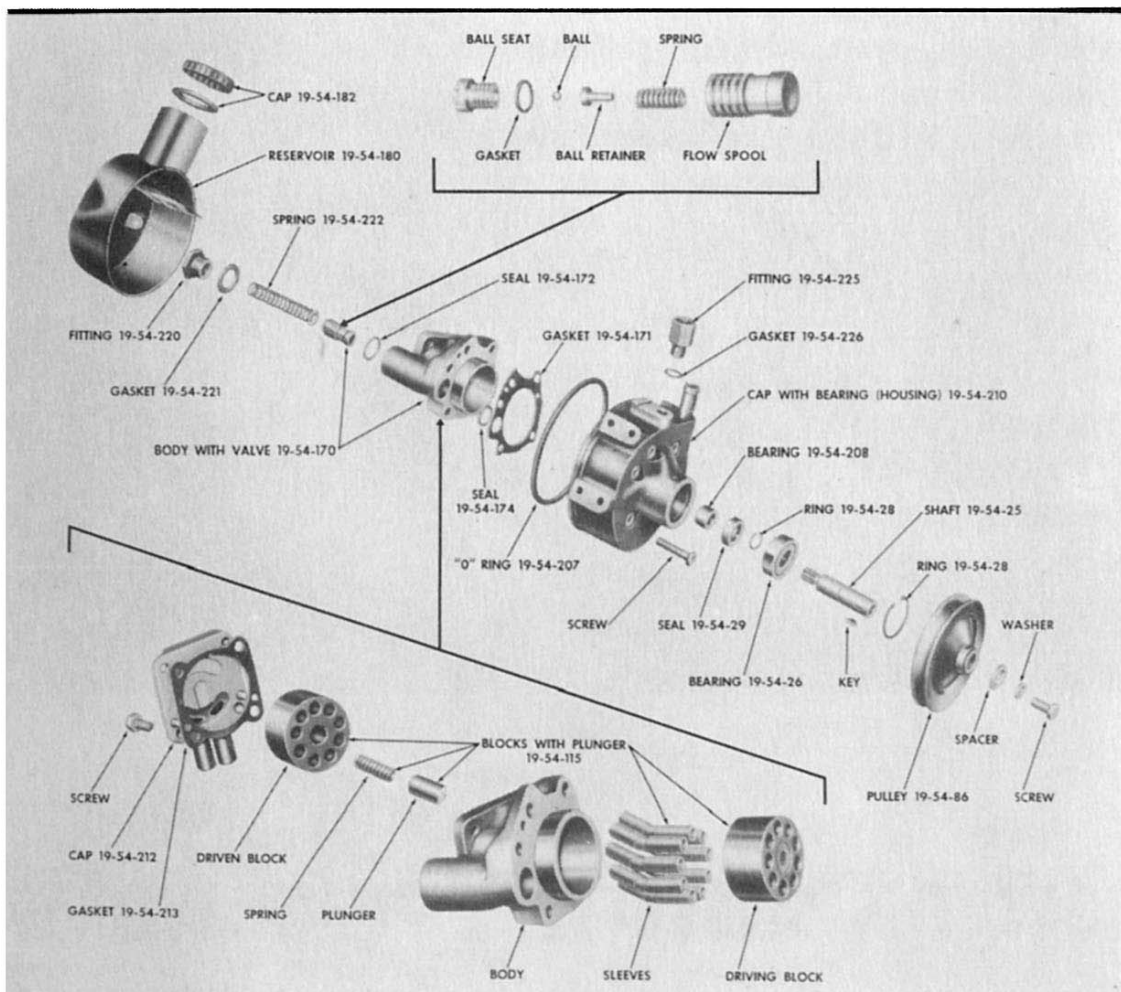

On 1957 Chrysler, Imperial and Plymouth cars, the power steering pump is of new design: it is known as a sleeve-type, positive displacement pump. Let's take a look at how it works.

Inside the sleeve-type pump body are two cylinder blocks. Both blocks have nine bores. There are also nine connecting sleeves, bent about 30°, that form nine tubular chambers. The front block, containing splines, does the driving. The other block is driven by the connecting sleeves.

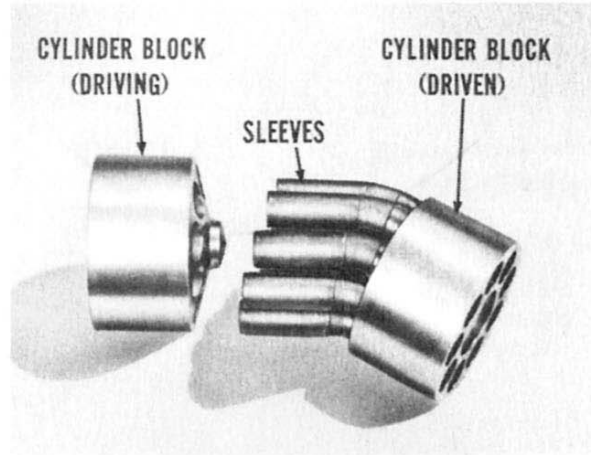

It's a lot easier to follow basic operation of the pump if you concentrate on what happens to one chamber during a complete cycle. For example, as one sleeve and both blocks turn one-half revolution, the chamber *increases* from its minimum to its maximum length. It goes from short to long.

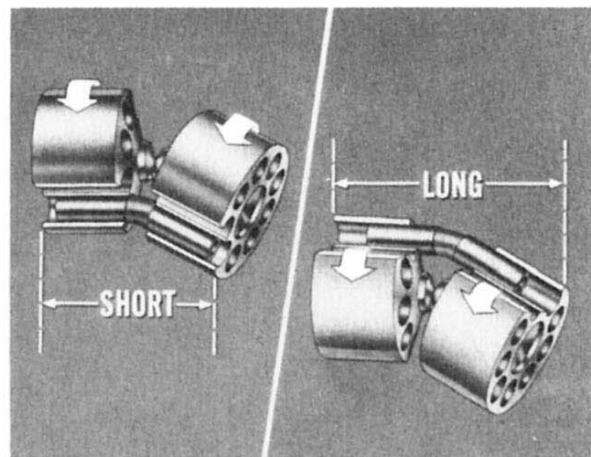

During the remaining half revolution, the chamber *decreases* in length. It goes from long to short. This change in chamber length provides positive displacement pumping action.

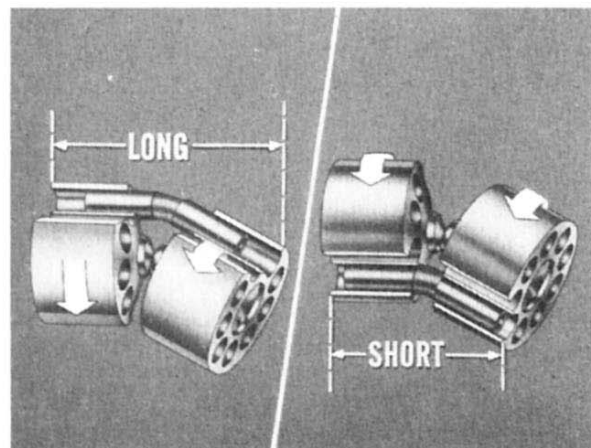

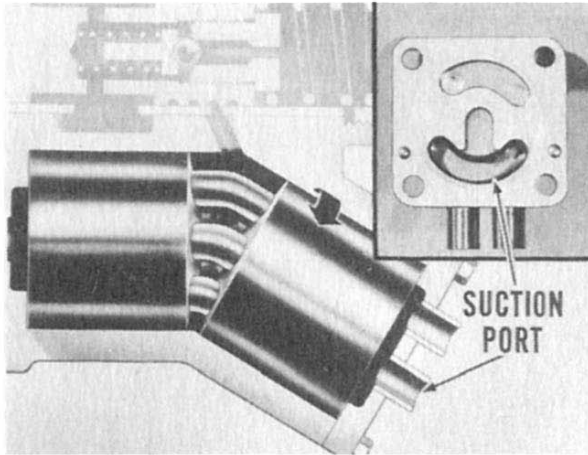

As the chamber gets longer, it draws oil in from a suction port in the end cap. This action is similar to what happens when a suction gun is used to draw oil out of a container.

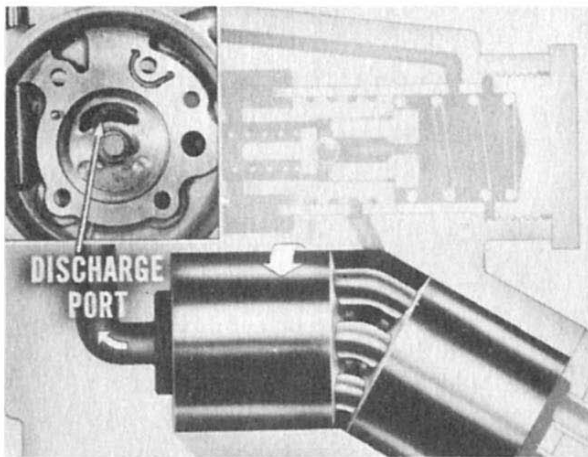

As the blocks continue to rotate, the chamber gets shorter. The oil passes through the sleeve and is forced out at the opposite end of the pump through a discharge port.

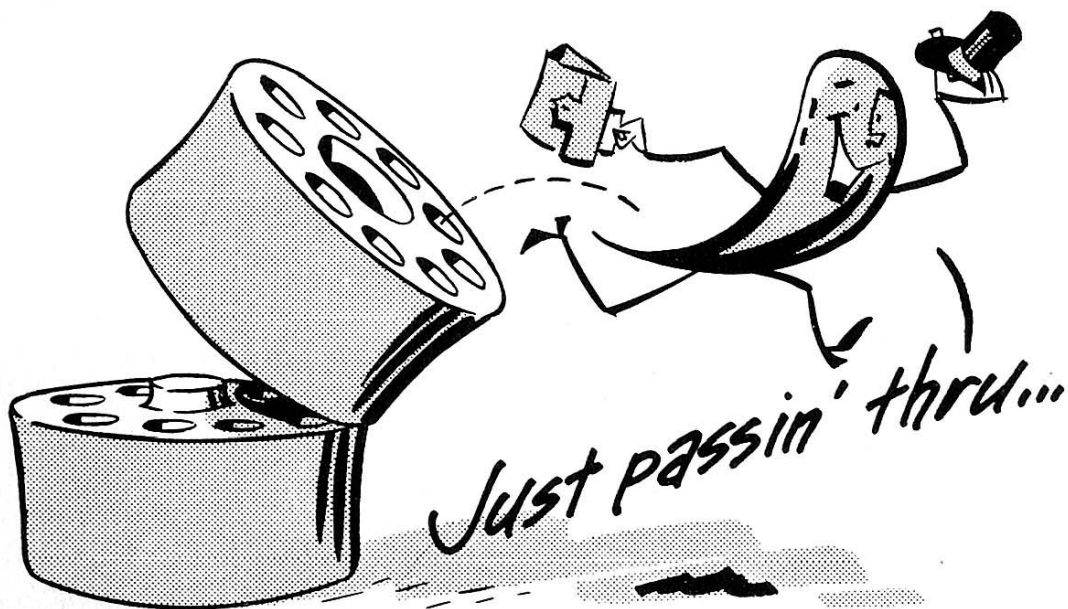

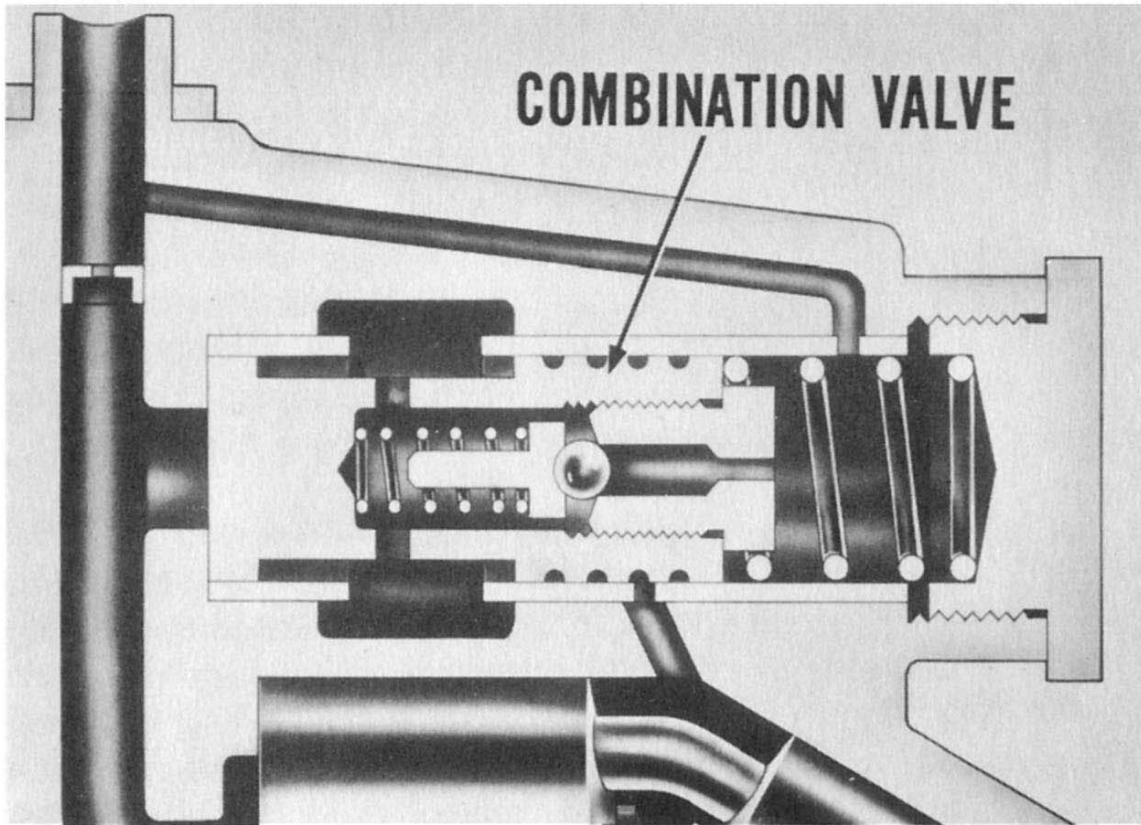

All of the oil displaced by the pump is discharged through a combination flow and pressure relief valve. This combination valve maintains a constant flow level, regardless of pump speed and pressure, and directs the oil to the steering gear.

One important thing to keep in mind is that all nine chambers, in turn, do the same job. Each chamber draws in oil, and discharges it. There's a continuous flow of oil under pressure to the steering gear.

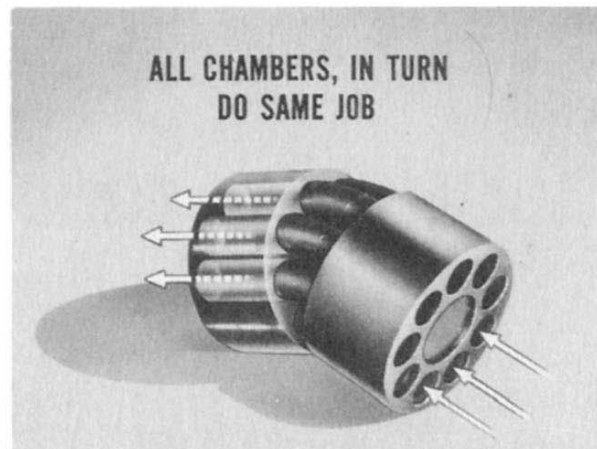

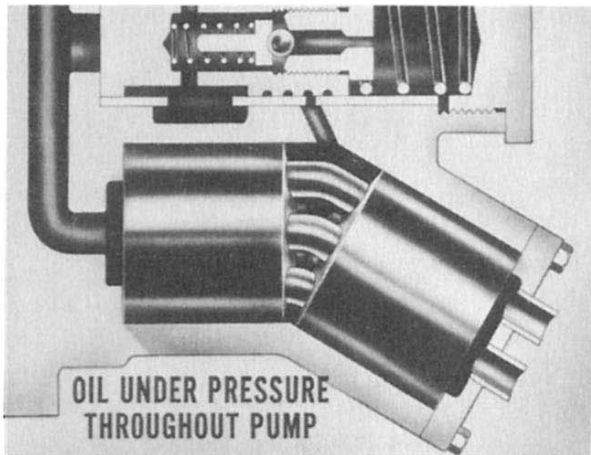

In fact, there's oil under pressure throughout the sleeve-type pump. As a result of small clearances, a tiny amount of oil finds its way between the sleeves and cylinder blocks into the center section, or knee, of the pump. So each internal part works smoothly on a film of oil.

Between both blocks, a spring and plunger are assembled. This

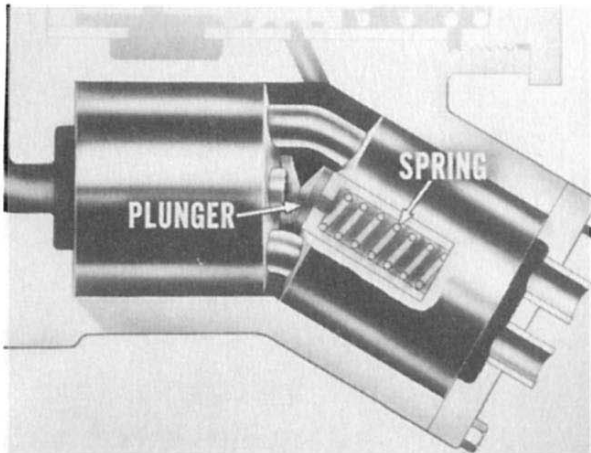

pushes both blocks out against the end cap and pump housing to form a seal, until pressure builds up. When that happens, fluid pressure in the space between the cylinder blocks forces the cylinders out to form a seal at the end cap and at the housing.

It is rarely necessary to get inside the pump body to locate the cause of below-standard pump performance. It's easier and wiser to check for causes *outside* the pump, such as loose or worn drive belts.

SOME PUMP CONDITIONS TO CHECK

If a sleeve-type pump isn't performing properly, there are three things to look at before taking anything apart. Check for loose or worn drive belts first. Next, see if the oil is up to level. Third, make a pressure test.

Here's a quick way to find out if the belt's too loose. With a torque wrench, try tightening the pulley attaching bolt. If the reading reaches 20 foot-pounds before the pulley starts to slip, tension is tight enough to prevent slippage.

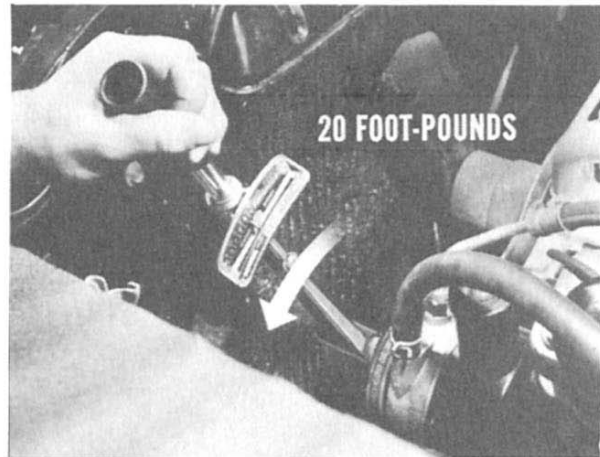

Next, check the fluid level. But before you make this check, be sure to wipe off the cap and filler neck. You can't be too careful about keeping dirt out of the pump. Always check fluid level in the reservoir when it is up to *normal operating temperature*. The fluid should be up to the level mark in the reservoir filler neck.



Use only automatic transmission fluid, type "A". But, as an emergency measure only, a small amount of S.A.E. 10-W engine oil can be used to bring the fluid up to the proper level. In extremely cold weather,



where there's a lot of below-zero temperature, S.A.E. 5-W may be used. Type "A" fluid is so viscous at extremely low temperatures, it could cause quite a drag on the starting motor. As soon as the cold weather period is past, however, drain the pump and use type "A" fluid, or mineral

spirits, to flush out the system. Then, refill with type "A" fluid. Engine oil won't do a satisfactory job in warmer weather.

NOTE:

Engine oils usually contain additives that may eventually deposit out on the working parts of the pump. This could lead to loss of pressure and even sticking of the flow valve. That's why it's important to drain and flush the system as soon as the extreme cold weather is past.

Lumpy, Hard Steering—On-Off Power Assist. Let's suppose an owner reports lumpy, or hard steering, near the end of a full left or right turn . . . or, on-and-off power assist. In either case, you still check belt tension and oil level first.

If tension and level *are* okay, your next step will be to find out whether the pump or the steering gear itself is at fault. The easiest way to do that, of course, is to check pressure output of the pump.

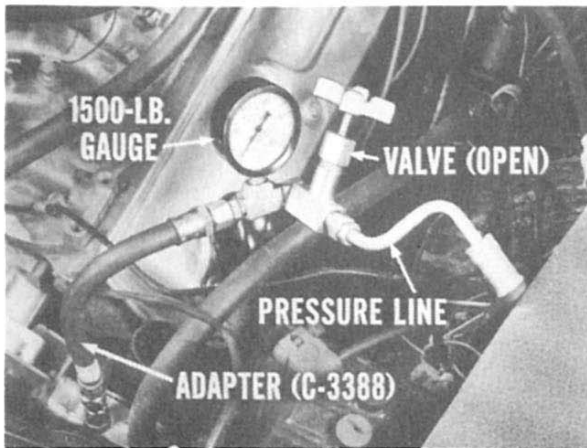

So, with the aid of a special adapter hose (C-3388), install a 1500-lb. pressure gauge (C-3309-B) in the pressure line between the pump and the gear. Make sure the gauge line valve is open so oil flow to the gear won't be restricted. Also, connect a tachometer as your guide to engine speed.

Then start the engine. Let it run until the pump reaches normal operating temperature which is about 175° F. Make sure engine idle is set at 475 to 500 r.p.m. Once that's determined, you're ready to close the gauge valve and shut off oil to the gear.

CAUTION:

Remember that pressures and temperatures in the power steering pump rise mighty fast, so the valve *shouldn't* stay closed more than 20 seconds!

Gradually close the gauge valve and watch the gauge as you do. Keep your hand on the valve to open it quickly if pressure starts to go higher than 950 psi. Pressure should rise to between 800 and 950 pounds. Open the valve after making this test.

If the gauge registers less than 800 psi, pump output is too low. Naturally, if pressure were found to be low, that would automatically rule out the steering gear as a source of the erratic condition and point to the pump as needing attention.

There are about three major causes of low pump pressure that you ought to check. For instance . . . low pressure could be caused by dirt holding the pressure relief valve open. It might be caused by loose end cap or pump body cap screws. Third, there might be some scoring inside the pump.

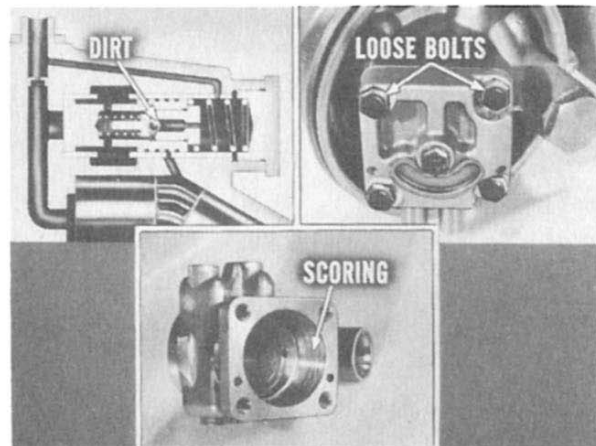

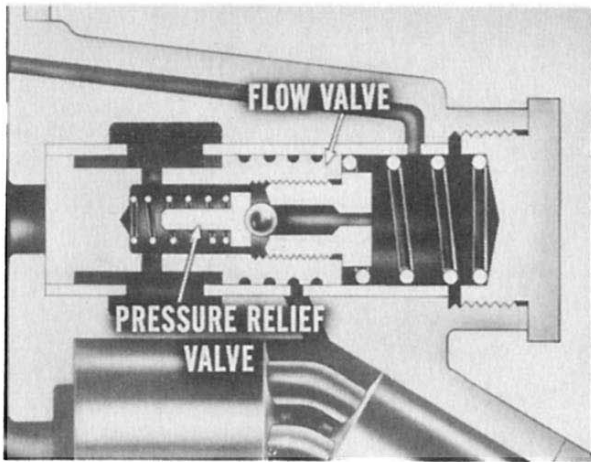

If the flow valve—or the pressure relief valve inside it—sticks open because of dirt, the pump may not provide steering assistance. More often than not, you'll find that checking the flow valve or pressure relief valve first will save you time and effort.

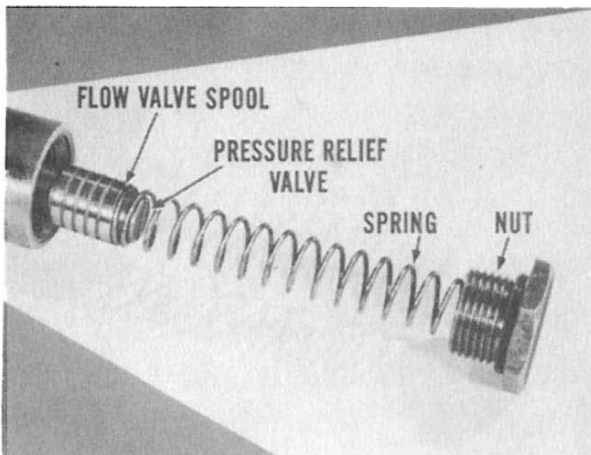

How to Inspect the Flow Valve. First step in examining the pump will be to remove it from the car and then drain it. Remove the reservoir. Next, unscrew the large hex nut that holds the flow valve and spring in the pump body. Remove the flow valve spool.

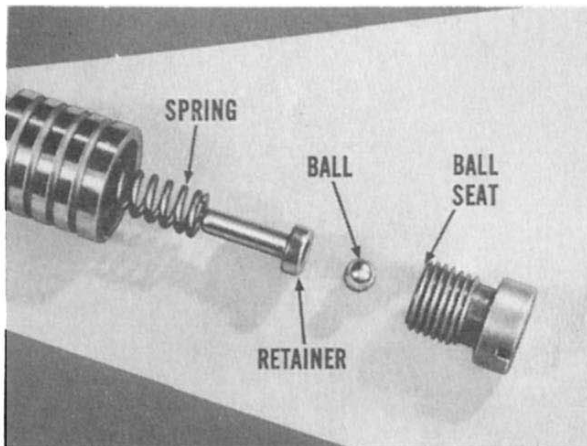

The pressure relief valve is inside the spool. So, remove the screw in the end of the spool. This screw is the pressure relief valve ball seat. Also, remove the ball, the ball retainer and spring.

Be sure to inspect the parts for evidence of dirt, burrs, or nicks that might have caused the valve to stick. A tiny piece of lint on the seat, for example, can prevent the ball from seating and result in lumpy or on-and-off steering assistance.



Inspect the parts in an attempt to find the cause of the condition *before* cleaning them. Occasionally, parts are dumped into solvent first, which removes the guilty particle of foreign matter, and the technician never quite knows what may have been causing improper pump operation.

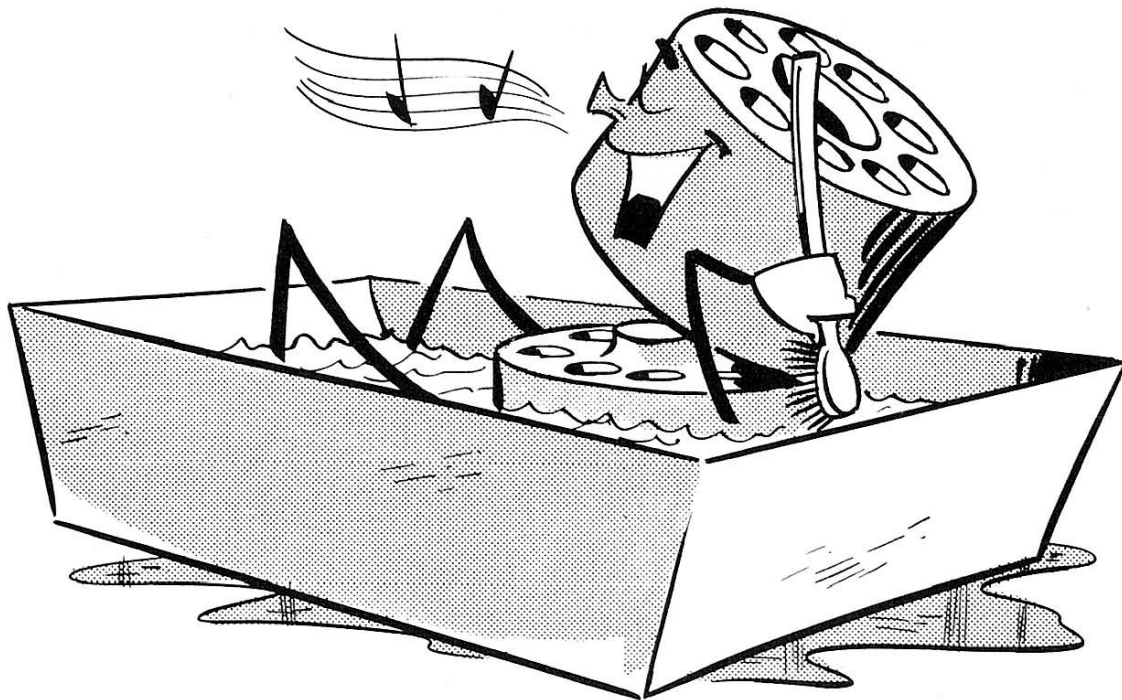

When cleaning parts, use solvent such as mineral spirits, so no sticky film will remain. Then use compressed air to dry the parts thoroughly. Inspect carefully for nicks and scratches, especially on the flow valve spool and valve liner.



Check the fit of the spool in the liner. It should slide through the liner by means of its own weight. If it sticks at any point, find the nick or burr responsible and polish it out. Recheck spool movement in the liner.

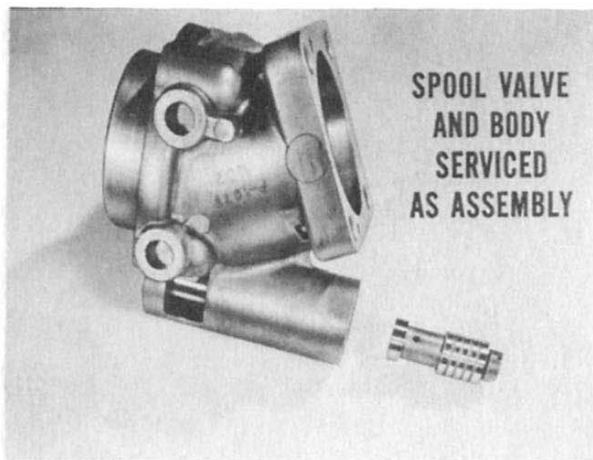

If you come across a rare case where any of the valve parts are badly scored, remember that the spool valve and pump body are serviced as an assembly.

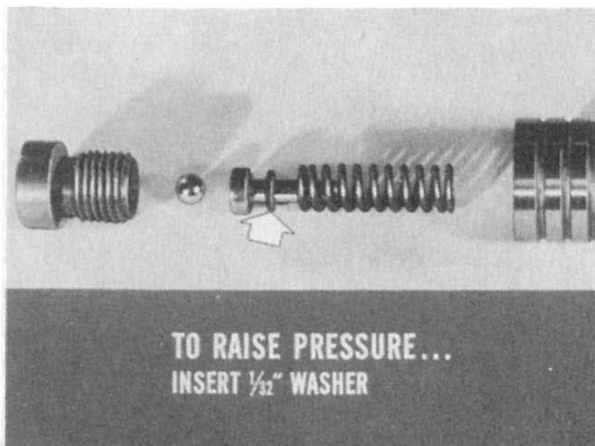

To raise pump pressure, you can insert a $\frac{1}{32}$ " washer (Part No. 1733017) between the spring and ball retainer, and then reassemble the valve. Install the pump and recheck the pressure.

If you should find nothing wrong with the spool valve assembly, it may be that loss in pressure was due to another cause.

For example, loose cap screws which hold the end cap to the body, or those which hold the body to the housing, could cause loss of pressure. You should get 15 foot-pounds torque on these screws. Don't tighten those screws any tighter than that as they thread into aluminum, and you may damage the aluminum threads.

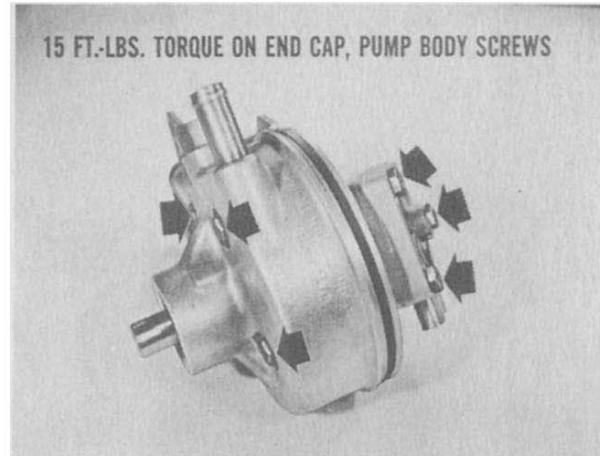

If these cap screws are tight, belt tension and fluid level are correct, you would suspect some internal damage to the pump as being the cause of low pressure.

So, disassemble the pump and inspect the cylinder blocks, sleeves, end cap and body for signs of excessive scoring. This, of course, can also cause low pressure. Keep in mind, though, that minor scratches or scuff marks on the blocks or the body won't hurt pump operation.

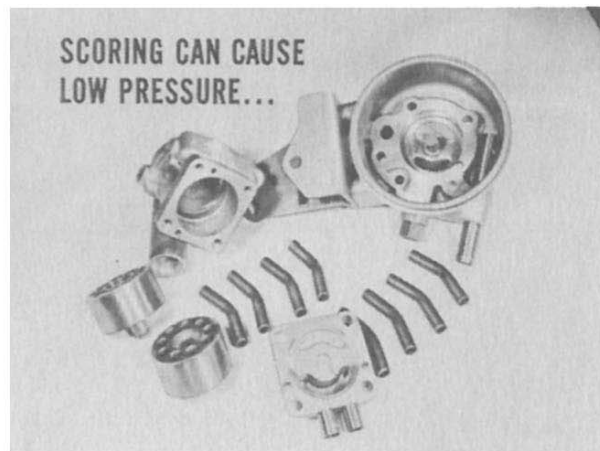

And if each sleeve has a smooth, slip fit in the bores, and some suction develops when you hold both ends closed as you withdraw the sleeve, the sleeve fit is probably all right.

HOW TO REASSEMBLE THE PUMP

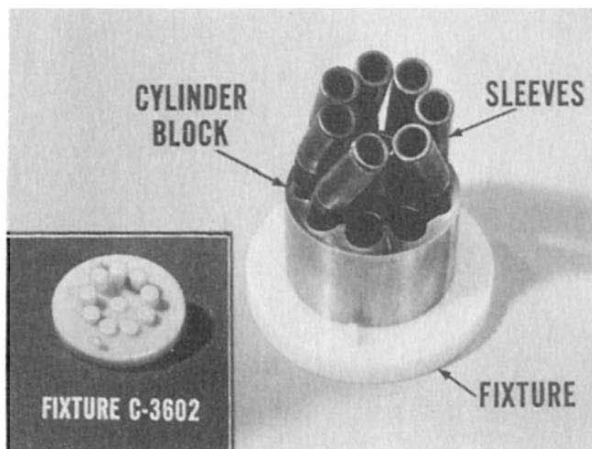

Use of the new assembly fixture (C-3602) is a must—it is next to impossible to assemble this pump without it. Place the driven block, the one without splines, on the fixture. Then, oil and insert the plunger spring, plunger and seven of the nine sleeves next.

Put the pump body over the block and fixture. Space the sleeves evenly, and insert the other two sleeves.

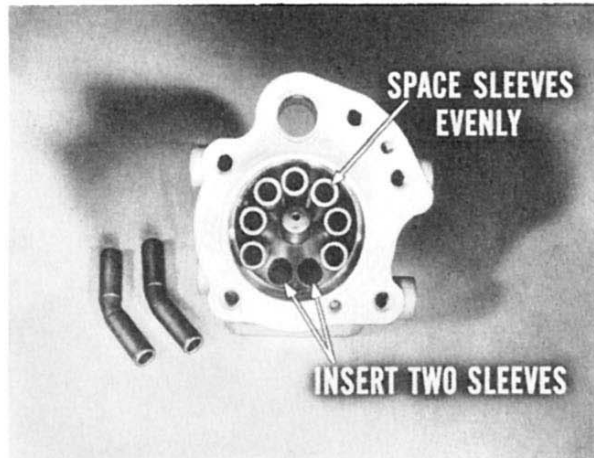

Place the splined block over the sleeves. Sight through the bores and lower the block until it engages the two sleeves in the forward position. Again, use the probe to align the next two sleeves while you push the driving block gently downward.

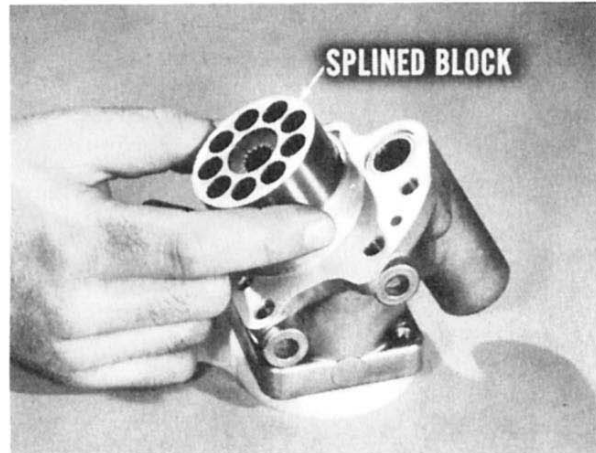

Line up the next pair of sleeves and gently guide the block down over them. Finally, line up the remaining sleeves and gently push the driving block all the way. Never force the driving block into place as it may bind; then the blocks will have to be taken apart, and the assembly operation started over again.

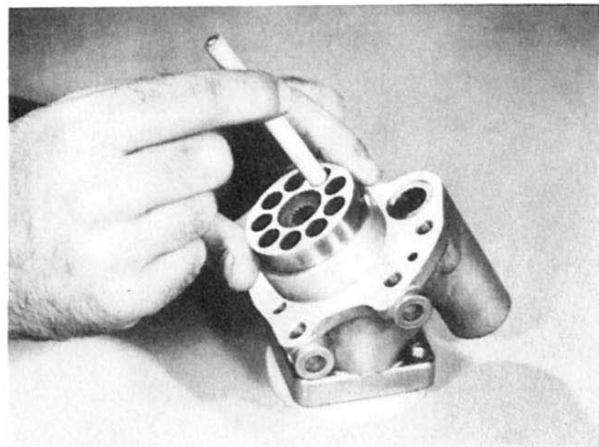



Remove the parts from the fixture next. Install the end cap, using a new gasket. Tighten the cap screws finger-tight to keep the driven block in place.

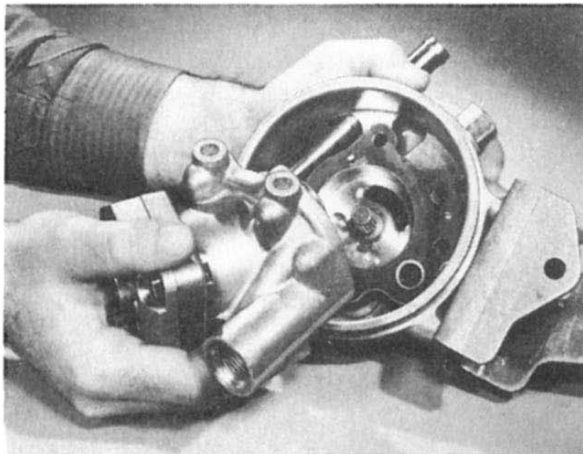

Then, assemble the pump body to the housing, making sure you use a new body gasket and a new flow valve seal ring.

Now, slip the pulley on the shaft and rotate the pump shaft. It should turn freely without any binding. Once you determine that there is no bind, torque the end cap and housing-to-body cap screws evenly to 15 foot-pounds. Recheck the pump shaft rotation again to



make sure it doesn't bind. Wrap a fan belt around the pulley to keep it from turning while you tighten the pulley cap screw to 20 foot-pounds. Finish assembling the pump. Install the pump in the car. Be sure that no dirt gets inside the pump assembly during any stage of installation on the car.

OTHER PUMP CONDITIONS

Loose Pump Pulley. On some pumps a $\frac{1}{16}$ " washer was used between the pulley and cap screw lockwasher at the end of the pump shaft. This washer bears against the pulley hub and pushes it into contact with the inner race of the shaft bearing. The pulley cap screw should be tightened to 20 foot-pounds.

In some cases, overtightening of the cap screw resulted in the washer bending so it bottomed against the end of the shaft. Actual pressure of the cap screw on the pulley, therefore, isn't great enough to keep the pulley tight on the shaft.

You can correct a condition of this kind by installing a $\frac{5}{32}$ " thick washer (Part No. 567331) in place of the $\frac{1}{16}$ " washer. If a pulley is allowed to operate loosely, the key, pulley hub, and the shaft will be damaged and all will have to be replaced. Damage to any other pump parts is unlikely, so a new shaft, key and pulley, along with the thicker washer will correct the condition.

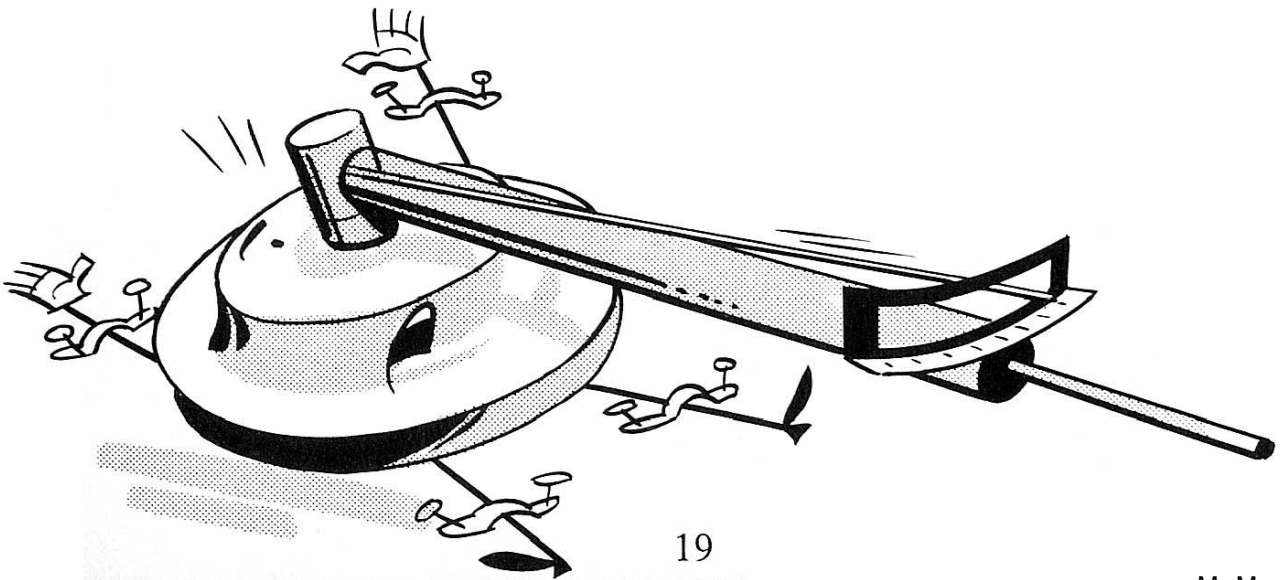
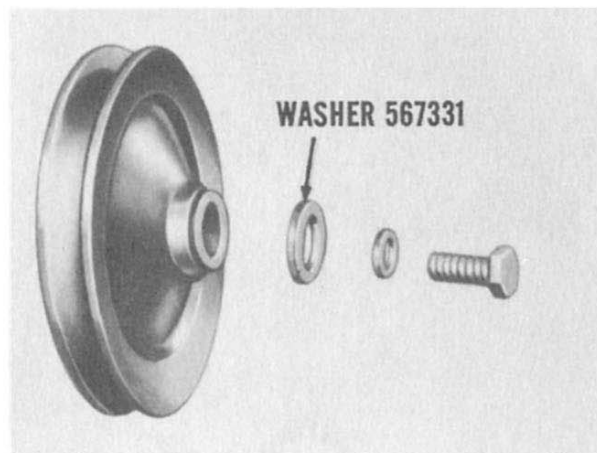

Inner Race Bearing Failure. Occasionally, overtightening the pulley cap screw may put too heavy a load on the bearing and the inner race may crack. Normally, this doesn't cause additional damage inside the pump unless the car is driven a considerable distance after the bearing may have failed.

To correct a condition of this type, disassemble the pump. Clean and inspect all parts to be sure no small particle remains inside. Reassemble the pump with a new pump shaft, a new pump shaft seal, new bearing, a new bearing retainer and new gaskets and seal rings. If the pulley hub and key have become damaged, replace these parts also.

TIPS ON SERVICING THE TOTAL-CONTACT BRAKES

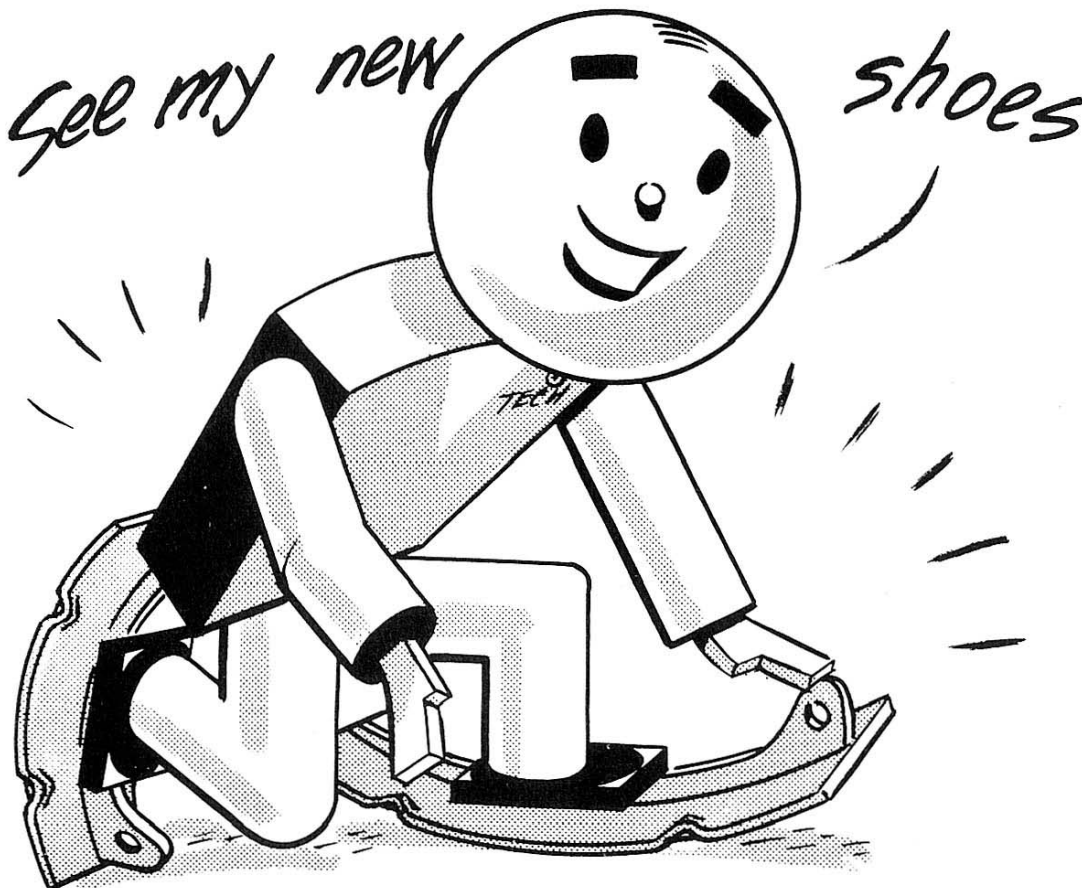

On the new brake shoe of the 1957 Total-Contact Brakes you'll notice special loops formed in the table. These loops contact the brake shield. This helps damp out shoe vibrations, which controls brake noise at its source.

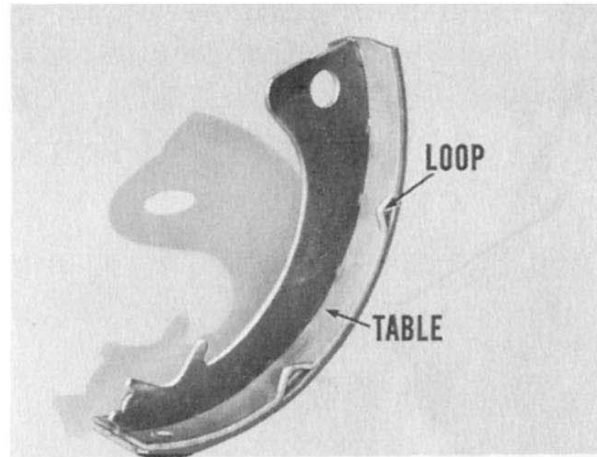

On front brakes, the shoe return springs are connected to a hole in the shoe web. On rear brakes, the return springs are hooked to another special loop in the table of the shoe. In case you're wondering about the difference in return spring mounting on front and rear brakes, here's the answer. You're more apt to hear the rear shoes because the rear axle housing acts as a sounding board.

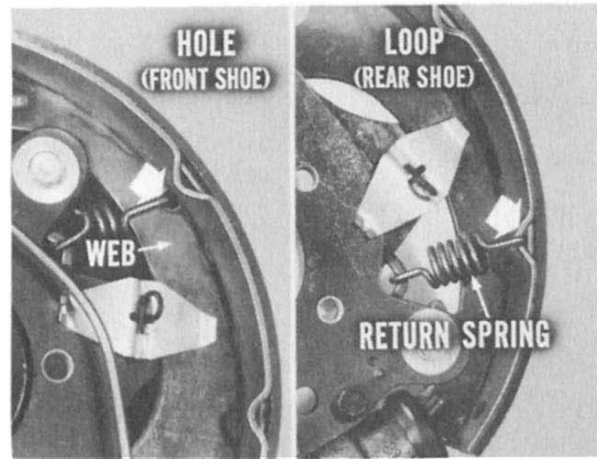

So, by hooking the return spring on the rear brake shoe off dead center, the shoe is pulled slightly sidewise and bears against the support plates. This helps damp out vibration.

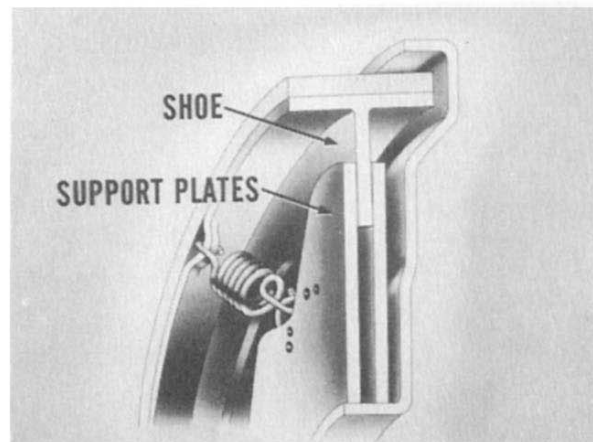

Brake Noise. Now, if you ever check into a case of brake noise, make sure the contact loops ride against the brake shield properly. Use a light and check from the anchor end of the shoe.

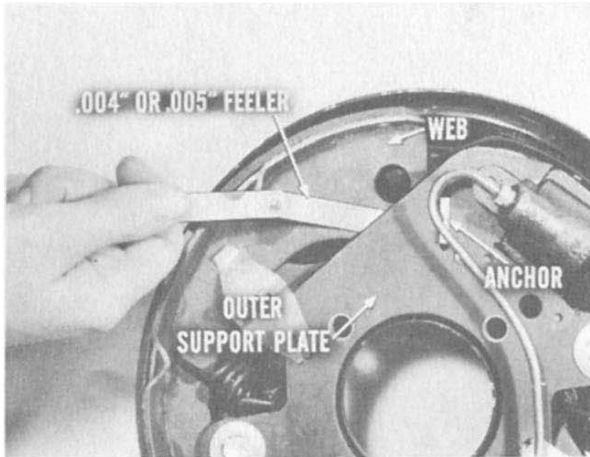

Slide a .004" or .005" feeler blade between the shoe web and outer support plate at the anchor end. If you can do it, there's no bind at that point, and the shoe is lined up okay.

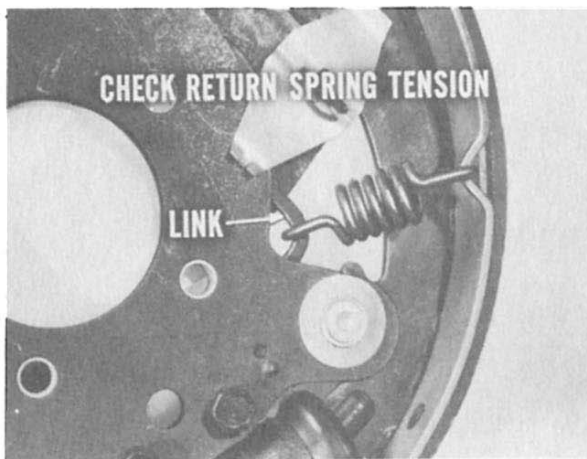

Check to see if there is proper return spring tension. Even a new spring won't return the shoe correctly if the link it hooks up with hangs up on the brake shield. You see, the link affects spring action. What's more, it automatically adjusts return spring tension whenever brake shoes are adjusted.

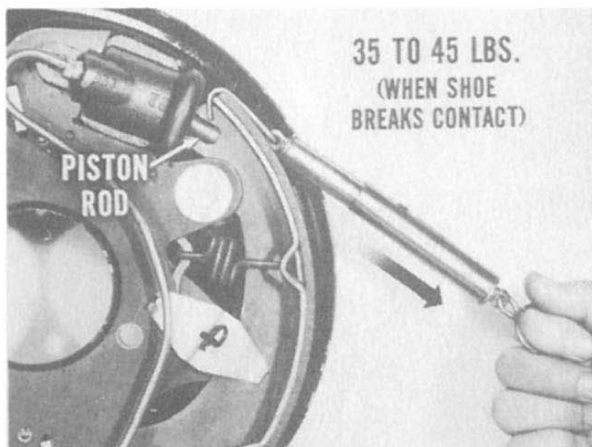

To check return spring tension, use a spring scale and pull the end of the shoe away from the wheel cylinder in the direction of piston travel. You should read 35 to 45 pounds when the shoe breaks contact with the piston rod.

Now, if tension is just a few pounds below the 35 minimum specified, try bending the hooked end to shorten spring length and to increase the tension.

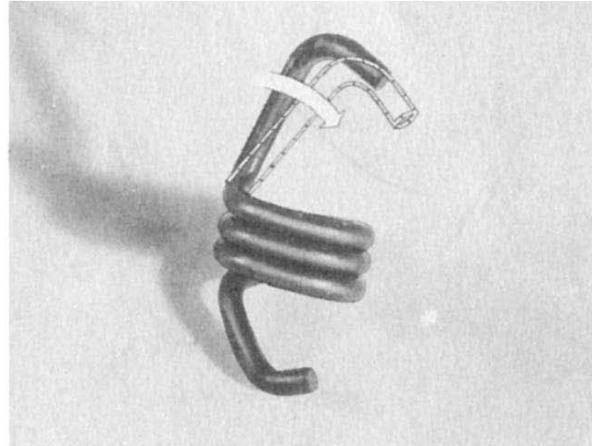

If that doesn't work, then install *new* return springs. Front brakes on Plymouth and Dodge take 3-coil springs. Other models take 4-coil springs. Rear brakes on Plymouth and Dodge use 6-coil springs. Other models use 5-coil springs.

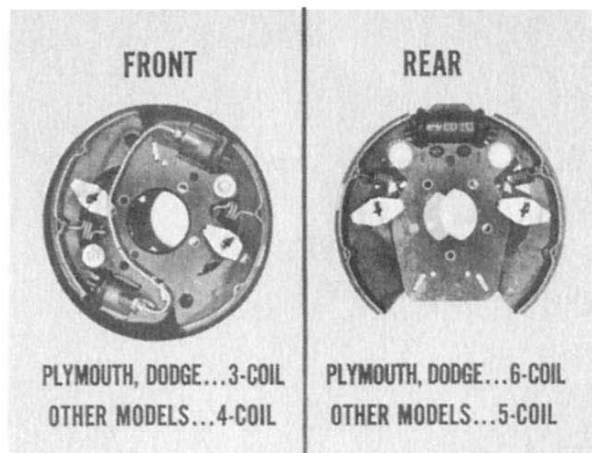

Another thing. At the anchor end of the shoe you'll notice a carefully designed cam contour which is mighty important for proper brake action. Don't ever file, or grind the cam . . . or the anchors. It will nullify the braking effectiveness of the shoe.

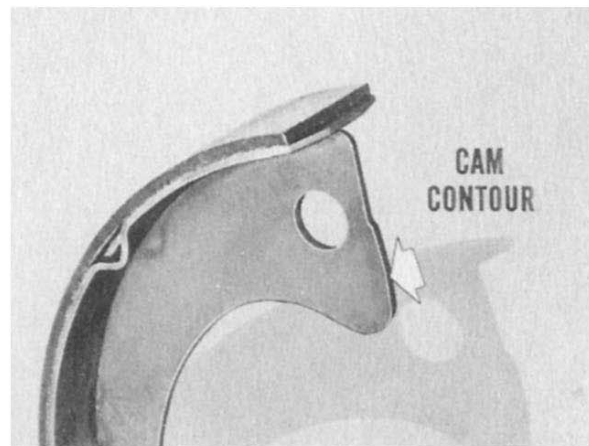

If an anchor gets loose, or the surface is badly scored, you'll have to install a whole new support plate assembly with new anchors.

Another point . . . always replace a brake shoe with a *factory-approved shoe*. That's because the genuine shoe is heat-treated at the anchor end to prevent wear, and the web is designed to permit a controlled flexing of the shoe under pressure. Look for a slight discoloring on the anchor end of the web as proof that it has been heat-treated.

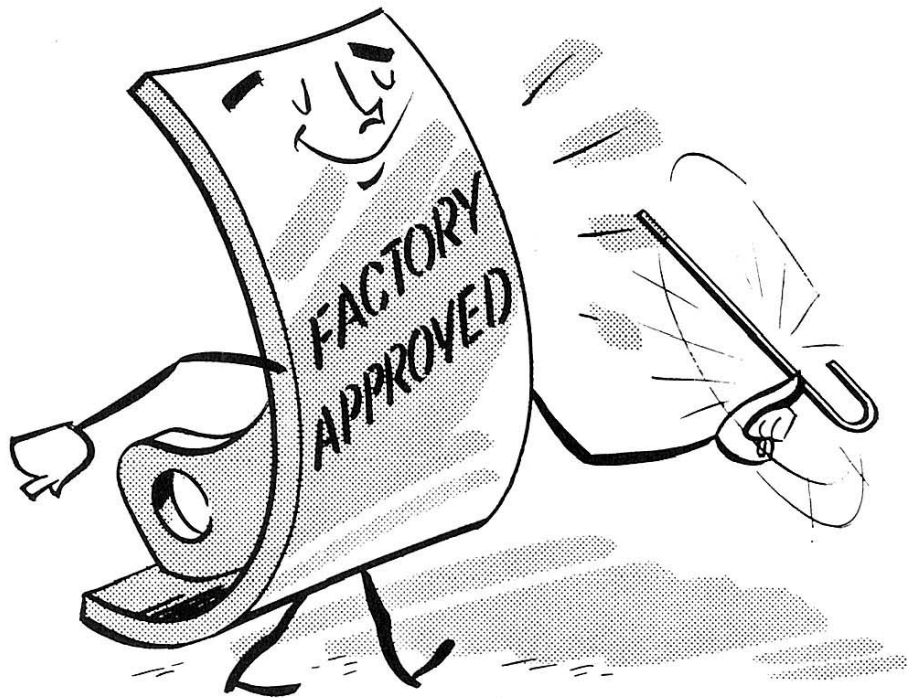

Glazed Deposits. Extensive use of the brakes, too, will overheat the drums. This, in turn, may leave a glazed deposit on the drums. This deposit, as you know, causes brake squeal, and reduces effective brake action. In a case like this, clean the drums and lining surface with number 200 or 300 emery paper.

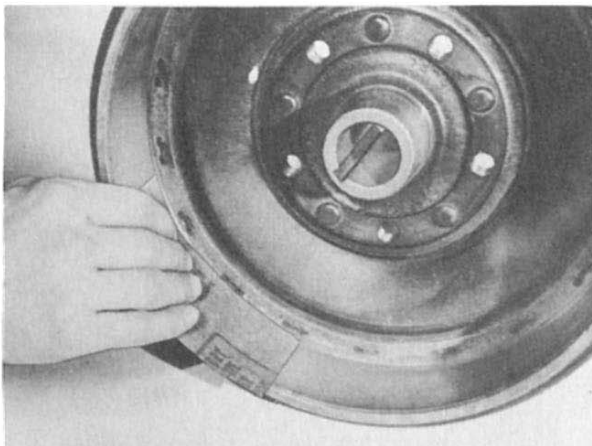

Grabby, Erratic Brakes. One more thing, if there is an opening between the wheel cylinders and brake shield, dirt and water can enter. That can cause erratic, or grabby braking, and even a high-pitched wire brush noise.

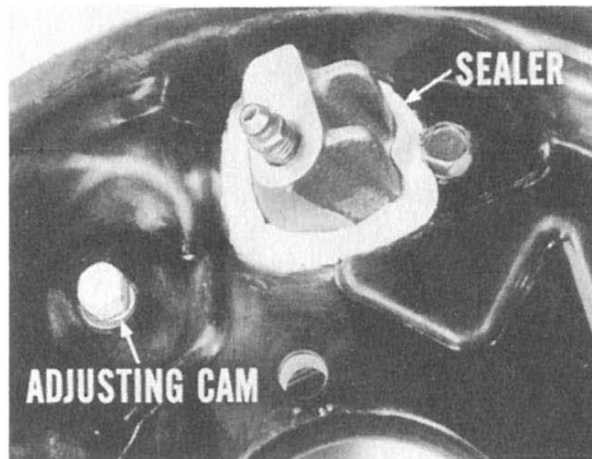

To correct this condition, clean the shoes and drums thoroughly. Use heavy body sealer outside the shield to seal off any openings. Always make sure the seal at each adjusting cam is in place, and in good condition, also.

Brake Adjustment. At this point it is in order to repeat brake adjusting information for the benefit of those men who may be working on Total-Contact Brakes for the first time. When adjusting *front* brakes, turn each adjusting cam in the direction of forward wheel rotation until the lining contacts the drum. Then turn the cam in the opposite direction just enough to permit the wheel to revolve freely, without brake drag. When adjusting *rear* brakes, turn the adjusting cam for the *front* shoe in the direction of *forward* wheel rotation, and turn the adjusting cam for the rear shoe in the direction of *rearward* wheel rotation, to force the lining in contact with the drum. Then turn the cam in the opposite direction until the wheel revolves freely.

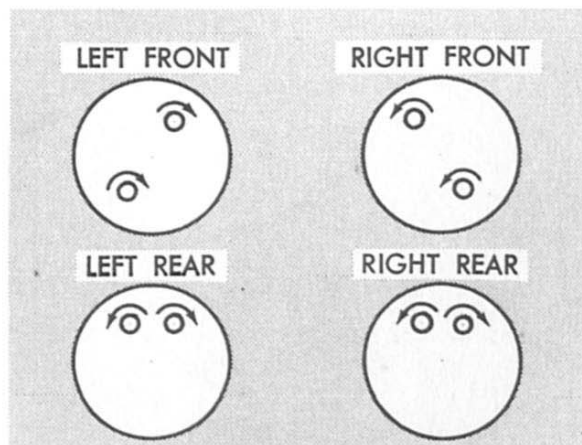

When it is necessary to remove a brake drum, always release the brake shoe adjusting cams to allow a little additional clearance be-

tween the lining and the drum. Failure to do this can result in damage to the support plates, lining, and even the drum itself.

SUMMARY

When it comes to service on power steering and brakes, we have to do our best work. After all, control of the car is the number one factor in driving safety. It is the responsibility of every Master Technician to see that nothing relating to safety is overlooked on any car that is turned over to him for service.

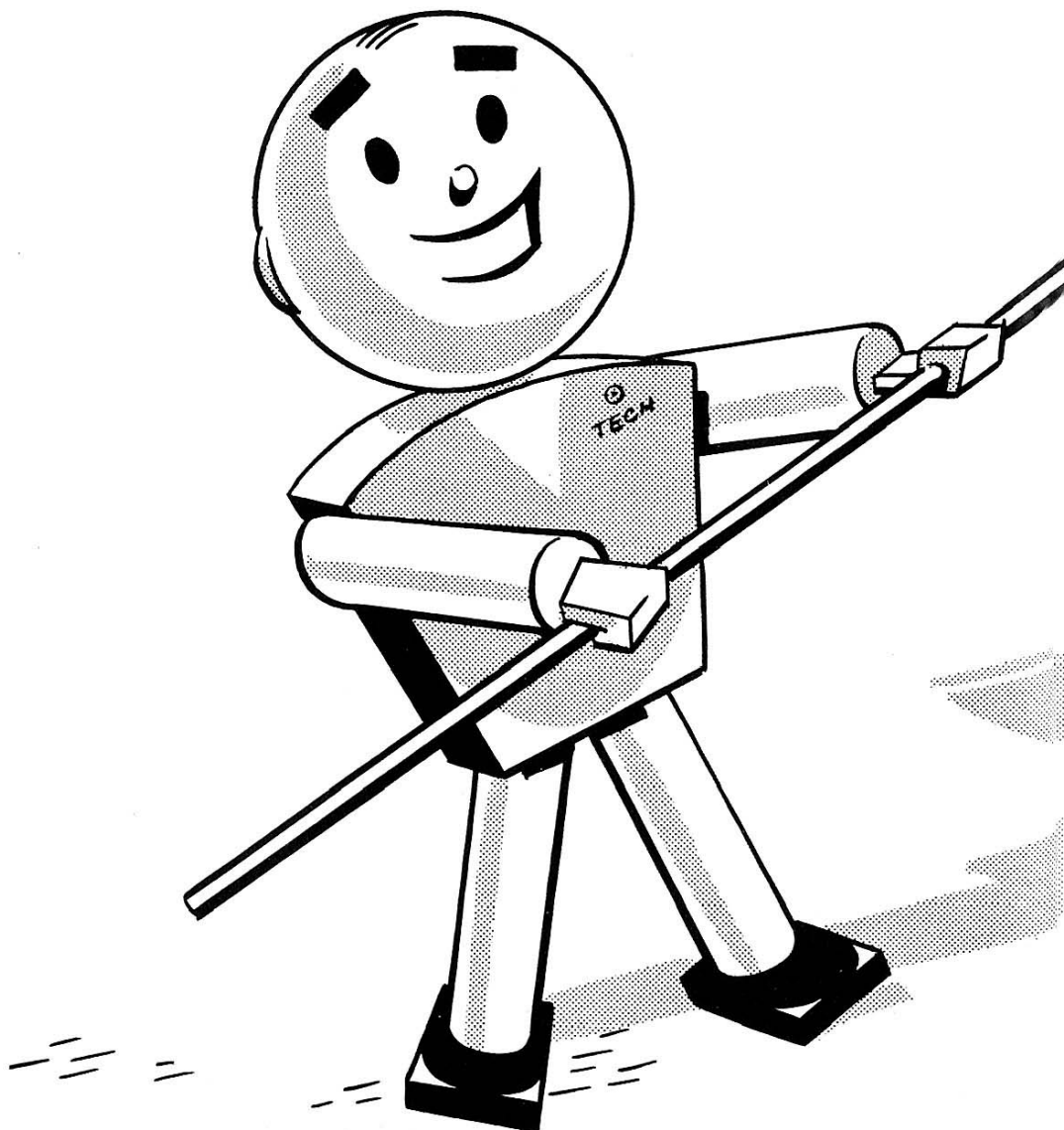



**RECORD YOUR ANSWERS
TO THESE QUESTIONS
ON QUESTIONNAIRE NO. 112**

- To locate the cause of poor sleeve-type power steering pump performance, look for outside causes first, before disassembling the pump. RIGHT 1 WRONG
- Before disassembling the power steering pump, check for (1) loose or worn drive belts; (2) fluid up to level; and (3) proper pump pressure. RIGHT 2 WRONG
- Pump pressure should rise to between 800 and 950 psi when the engine is idling at 475 to 500 r.p.m. and there's no pressure on the steering wheel. RIGHT 3 WRONG
- Low pump pressure could be caused by a sticking valve, loose end cap or body cap screws, or scoring inside the pump. RIGHT 4 WRONG
- Minor scratches or scuff marks on the cylinder blocks or pump body are good reasons to replace the entire pump. RIGHT 5 WRONG
- To remove glazed deposits on brake shoes and drums, use any grit sandpaper or emery cloth available. RIGHT 6 WRONG
- The major cause of brake noise is vibration of some part of the brake assembly. RIGHT 7 WRONG
- Brake shoe return spring tension should be between 35 and 45 pounds, measured at the toe end of the shoe with a spring scale. RIGHT 8 WRONG
- Never file or grind that carefully designed cam contour at the anchor end of the shoe web, because it is important to proper brake action. RIGHT 9 WRONG
- All openings in the brake shield must be sealed to prevent dirt and water from entering the brake assembly. RIGHT 10 WRONG

Litho in U.S.A.