

Service
Reference
Book no. **121**
of the
Master Technicians
Service Conference

THE NEW AFB CARBURETOR

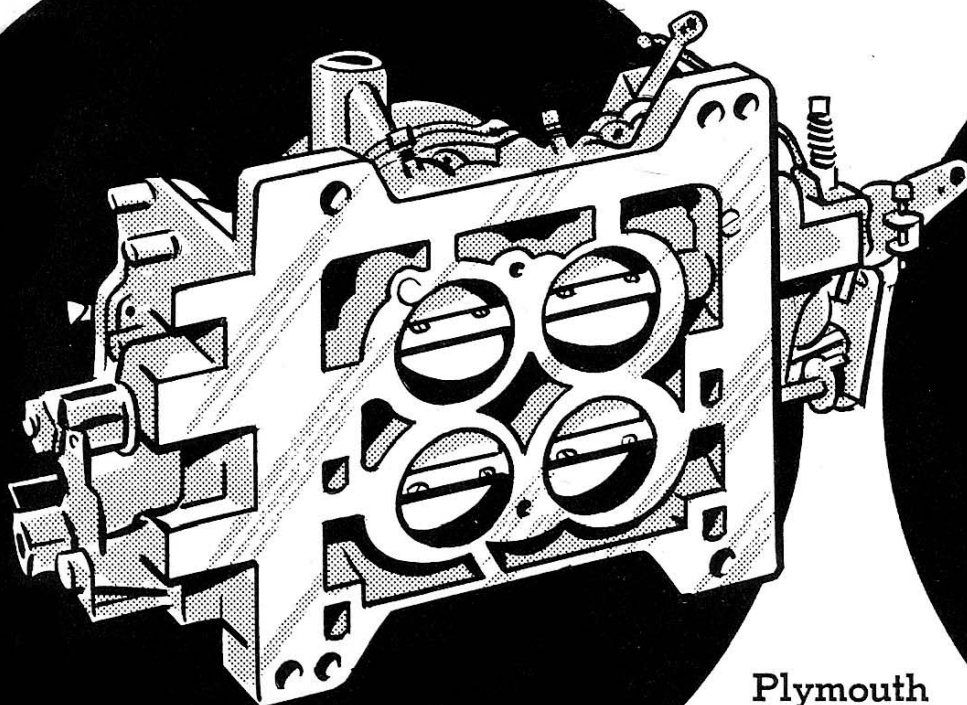

Plymouth
Dodge
De Soto
Chrysler
Imperial

Prepared by **CHRYSLER CORPORATION**

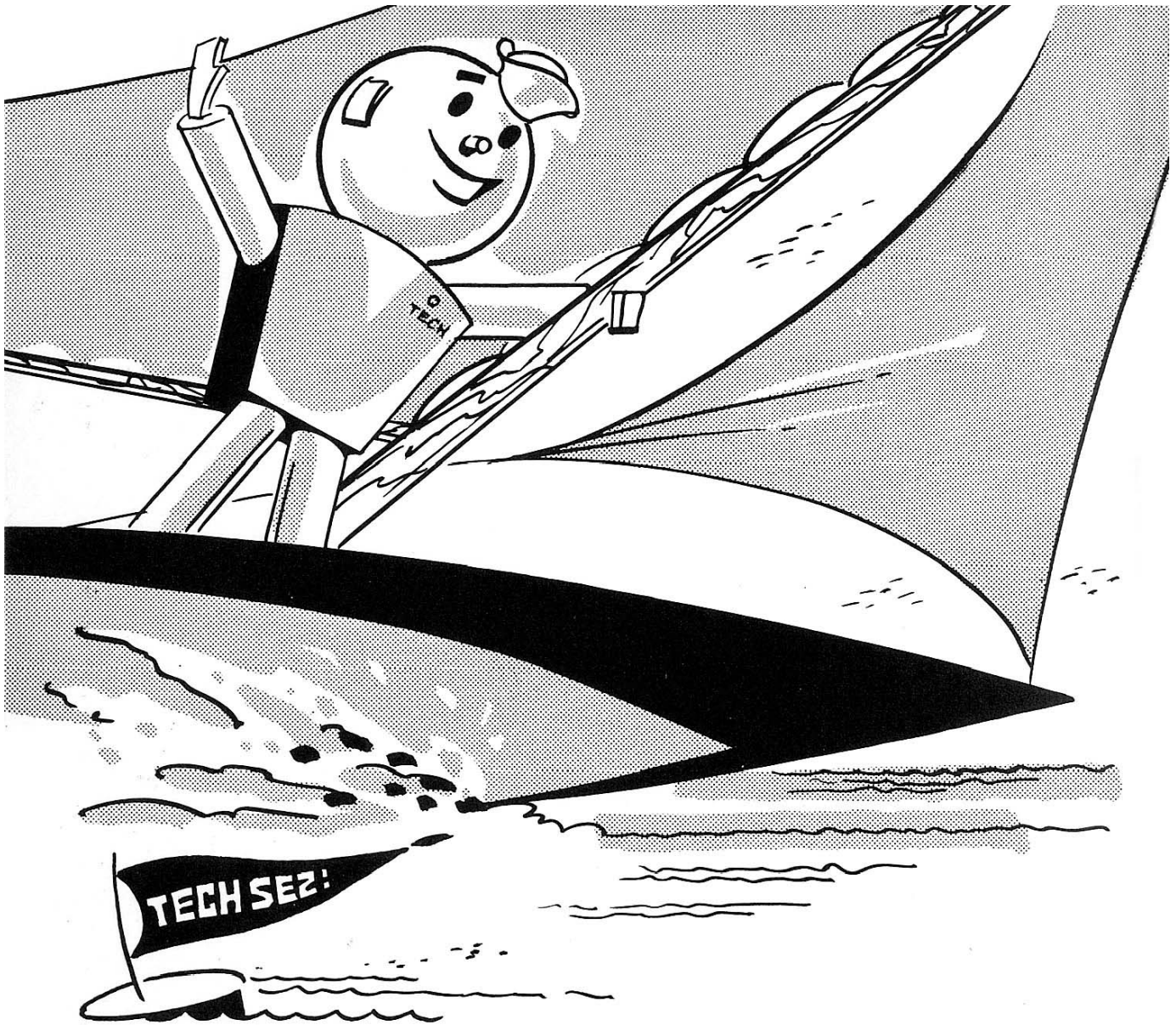

"YOU'LL HAVE SMOOTH SAILING ON AFB-CARBURETOR SERVICE!"

There's fair weather ahead for you on AFB-carburetor service. Actually, this new carburetor is easy to clean, adjust, or service.

Always keep in mind that the carburetor's the last thing to check when you're trying to correct sub-standard engine performance. Other tune-up bases such as compression and ignition should be tagged first. And when you've ruled out those possibilities, this reference book will outline procedures to follow on the carburetor.

There's information on removal, disassembly, cleaning, reassembly, adjustment, and installation. And here's your guide to helpful tips on operations you might have to perform.

	<i>Page</i>
DESCRIPTION	4
GENERAL	4
LOW SPEED SYSTEM	5
HIGH SPEED SYSTEM	6
SECONDARY HIGH SPEED SYSTEM	8
MAINTENANCE	8
REMOVE CARBURETOR	9
REMOVE AIR HORN	9
CHECK FLOAT ADJUSTMENT	11
REMOVE AND INSTALL BAFFLES	13
REMOVE PRIMARY VENTURI	13
ADJUST PRIMARY AND SECONDARY THROTTLE LINKAGE ..	14
ADJUST SECONDARY THROTTLE VALVE LOCK-OUT	15
ACCELERATOR PUMP SYSTEM	15
ADJUST PUMP STROKE	16
CHOKE SYSTEM	17
ADJUST INTEGRAL-TYPE CHOKE	17
ADJUST CROSSOVER-TYPE CHOKE	17
ADJUST FAST IDLE CAM LINKAGE	17
ADJUST FAST IDLE SCREW	18
ADJUST CHOKE UNLOADER	19
ENGINE IDLE ADJUSTMENTS	19
ADJUST IDLE SPEED	19
ADJUST IDLE MIXTURE	19
MODELS USING DUAL AFB CARBURETORS	20
VELOCITY VALVES	21
AIR BYPASS SCREW	21
FINAL ADJUSTMENTS ON CAR	21
ADJUST THROTTLE CONNECTOR ROD	22
ADJUST IDLE SPEED, IDLE MIXTURE	23



DESCRIPTION

General. The AFB (Aluminum Four Barrel) carburetor is in pretty general use on our 1958 line of cars. It is an entirely new design, and has been greatly simplified from previous four-barrel models.

The carburetor consists of two main castings instead of three, and the castings are of aluminum. The four barrels consist of two primary barrels and two secondary barrels. The primary barrels take care of engine requirements up to about two-thirds throttle opening. Then the secondary throttle valves start to open, and reach wide-open position at the same time the primary throttle valves are wide open.

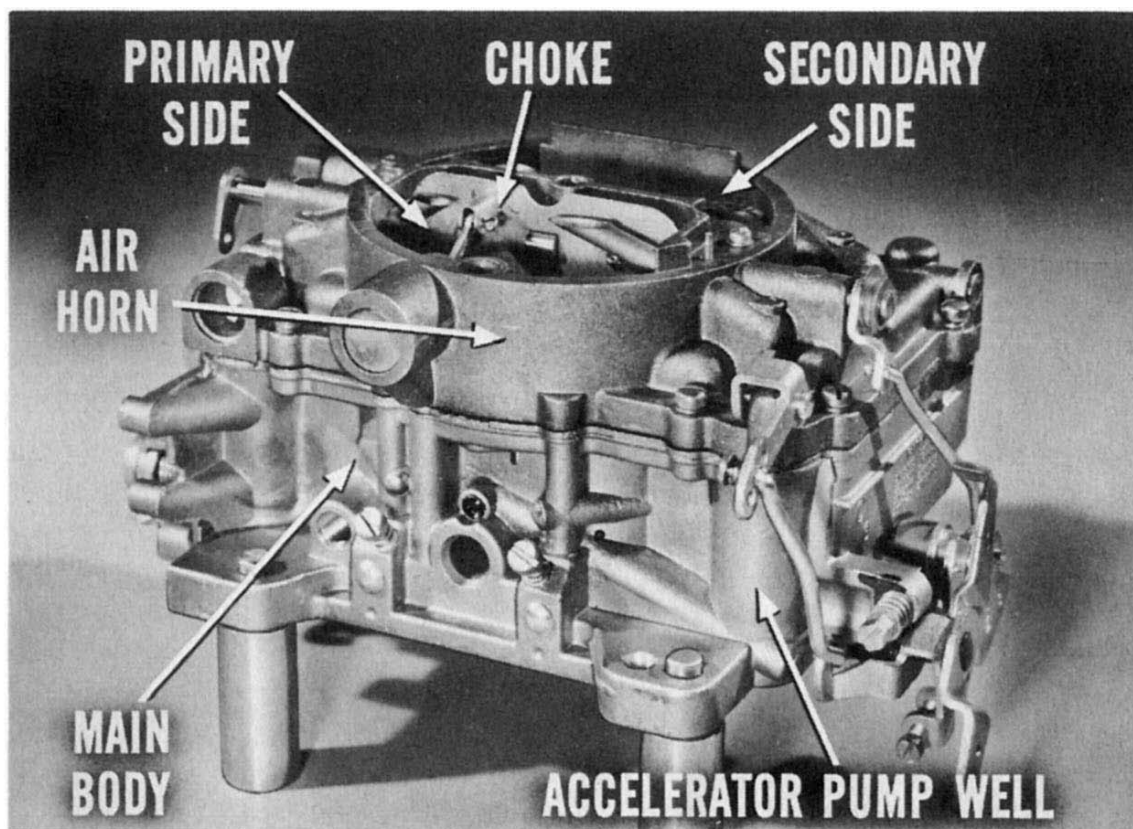

The carburetor functions as two two-barrel carburetors. There are two float systems, for example, each float serving one primary and one secondary barrel; two low speed systems (one for each primary barrel, since the secondary barrels do not function in the low speed range); two high speed systems—primary and secondary. The accelerator pump system takes care of both primary barrels, and the choke system applies to the primary barrels only.

One outstanding feature of the new AFB carburetor is the fact that each venturi is removable. Each primary venturi contains an idle air bleed, idle jet, high speed nozzle and a main vent tube. Each secondary venturi contains a high speed air bleed, high speed nozzle and main vent tube. Cleaning these passages is greatly simplified because of the removable venturi.

Low Speed System. A relatively rich mixture is needed when the throttle valves are closed, or partly closed, for idle or low speed operation. That's why a low speed system is needed. On the AFB car-

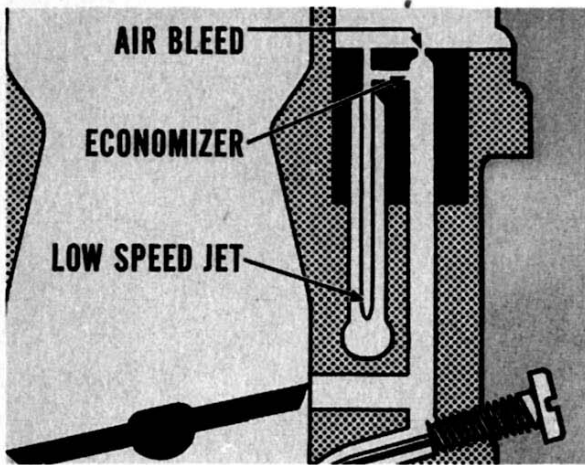

buretor, the low speed system functions in the primary barrels in the primary venturi assemblies. Low speed jets are pressed into the primary venturi assemblies. Bypass air passages, an economizer and an idle air bleed built into the assembly function to break up liquid fuel and mix in the air before the mixture gets to the idle and low speed ports.

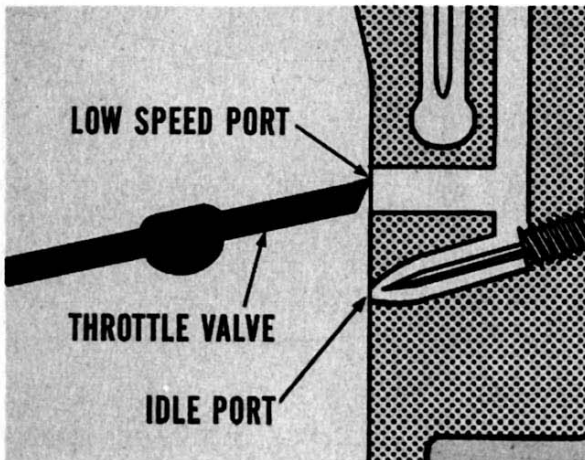

The low speed port is the slotted port just above the idle speed port. As the throttle valve opens it uncovers more of the port, allowing a greater quantity of the mixture to enter the barrels.

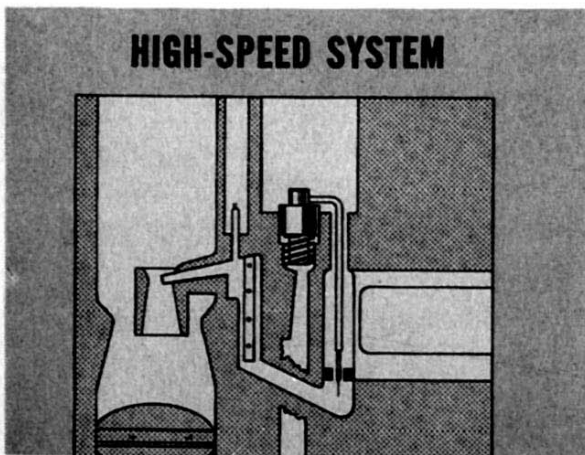

High Speed System. The high speed system supplies fuel for part and full throttle operation. The two front barrels contain the primary high speed system, and the two rear barrels contain the secondary high speed system. The flow of fuel to the main nozzles of the primary system is controlled by vacuum-operated step-up rods.

Manifold vacuum acts on a vacuum piston. The step-up rod is attached to the piston, and enters the main metering jet. The rod contains two diameters in the area which enters the metering jet.

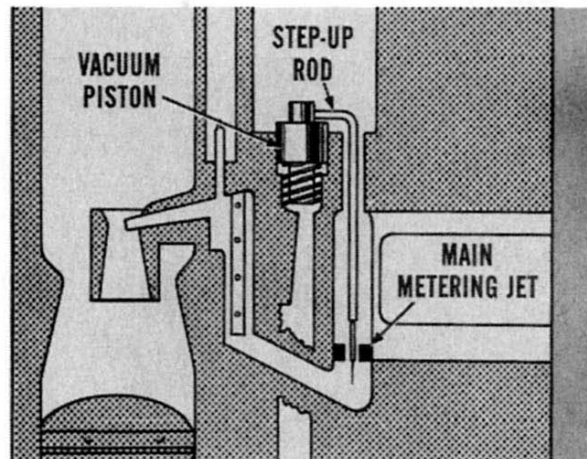

During part-throttle operation manifold vacuum is high. It pulls the step-up piston and rod down against a spring. This places the large diameter area of the rod in the metering jet, resulting in a reduced flow of fuel through the jet.

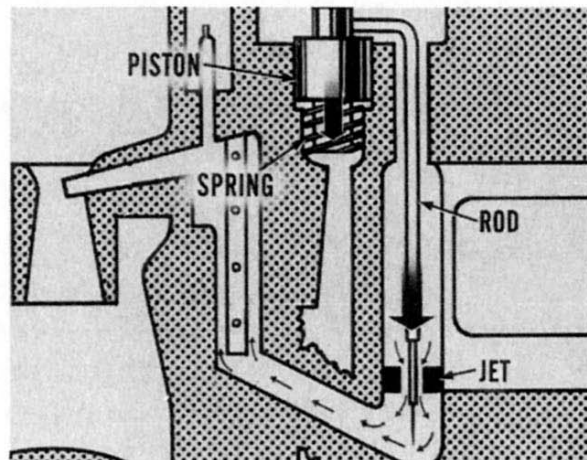

During wide-open throttle operation manifold vacuum is low. The piston spring overcomes the vacuum pull on the piston, and forces the piston up. The rod moves up until the small diameter area is in the jet. This permits an increase in the flow of fuel through the jet.

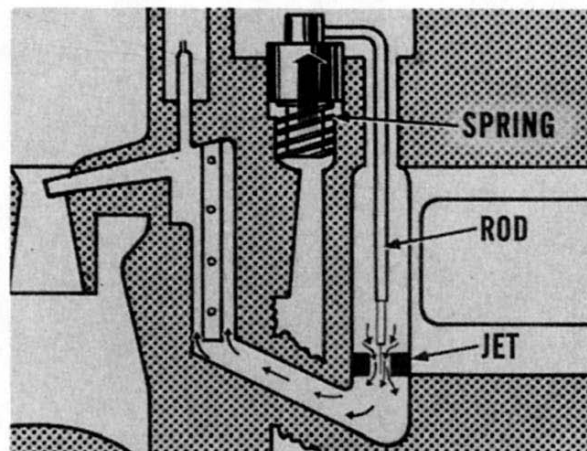

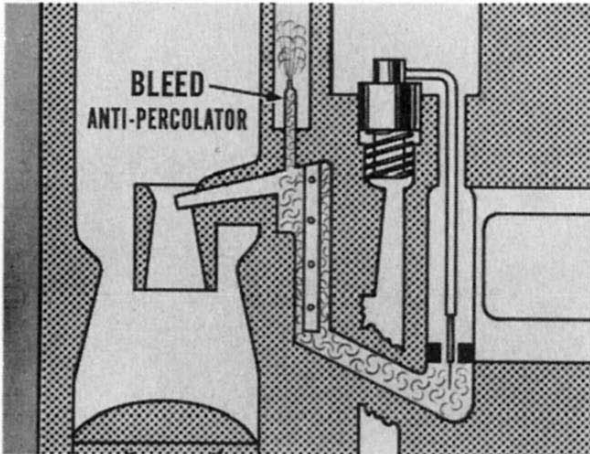

The high speed air bleed also serves as an anti-percolator vent. When a hot engine idles, or stops, vapor pressure in the idle well escapes through this vent. Otherwise, vapor pressure would build up in the idle tube and push fuel out of the nozzle and into the intake manifold, causing flooding.

Secondary High Speed System. In the secondary high speed system, fuel is metered at the secondary metering jets in the float bowls. No step-up rods are used.

MAINTENANCE

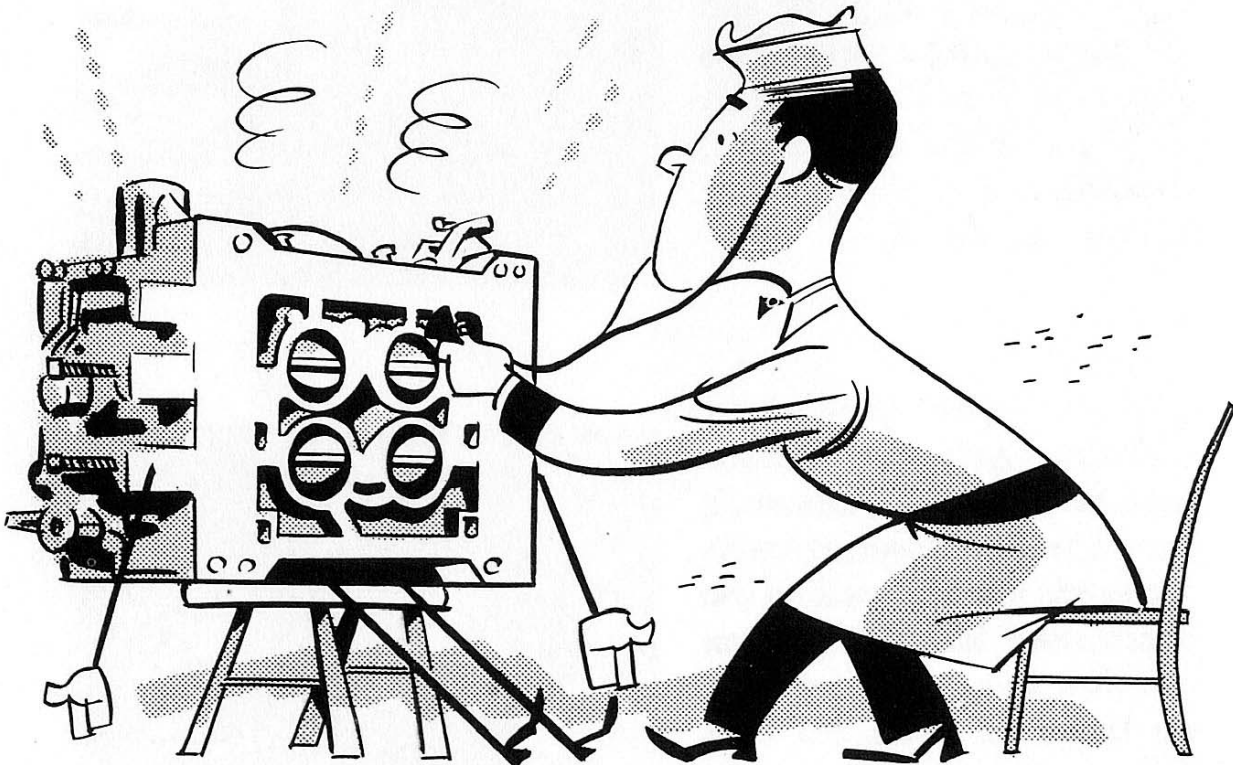

Most of the adjustments of the AFB carburetor can be made while the carburetor is installed on the engine. Some of them, particularly

those which would normally be performed only during a complete reconditioning job, require that the carburetor be removed. For the sake of providing complete coverage, therefore, this section will detail the adjusting procedures as they apply to a carburetor mounted on a reconditioning stand.

Remove Carburetor. No special instructions are required for the removal of the carburetor from the engine. There is, however, one recommendation; *do not drain the carburetor bowls*. Handle the carburetor carefully so you do not spill the fuel from the bowls until after the air horn has been removed.

The reason for this recommendation is that dirt is the chief cause of carburetor malfunctions. If you are checking for a particular condition that could be caused by dirt in the jets, or a plugged air bleed, you'd like to find the dirt to prove your diagnosis. If you drain the fuel from the carburetor before you examine it thoroughly you might wash out the dirt with the fuel. Then you would be unable to find the condition responsible for the poor performance, and would waste a lot of valuable time making other examinations and tests.

Remove Air Horn. The first step in the disassembly of the carburetor is to remove the air horn. This permits you to inspect for dirt in the float bowls, and to check float level. The step-up pistons and rods are assembled to the air horn, and will come out of the main body when the air horn is lifted off. However, it is much easier to install the air horn before the pistons and rods are installed. So, hold the cover plate down as you remove its screw, to prevent the piston, rod and spring from flying out. Remove the piston, rod and spring from each side. Handle the spring carefully so it will not be damaged.

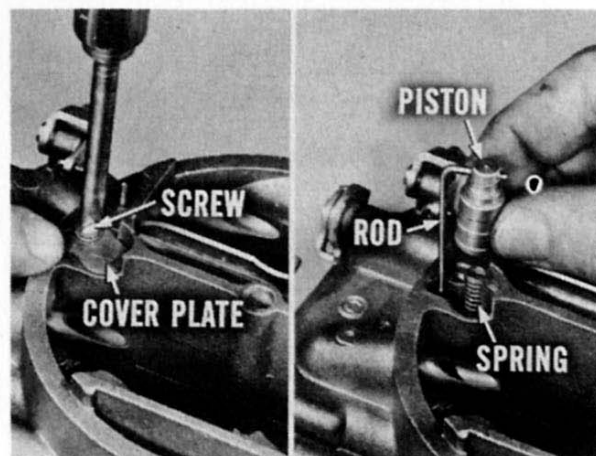

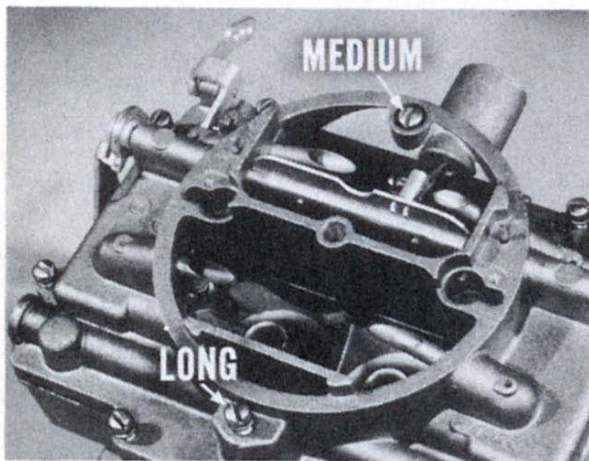
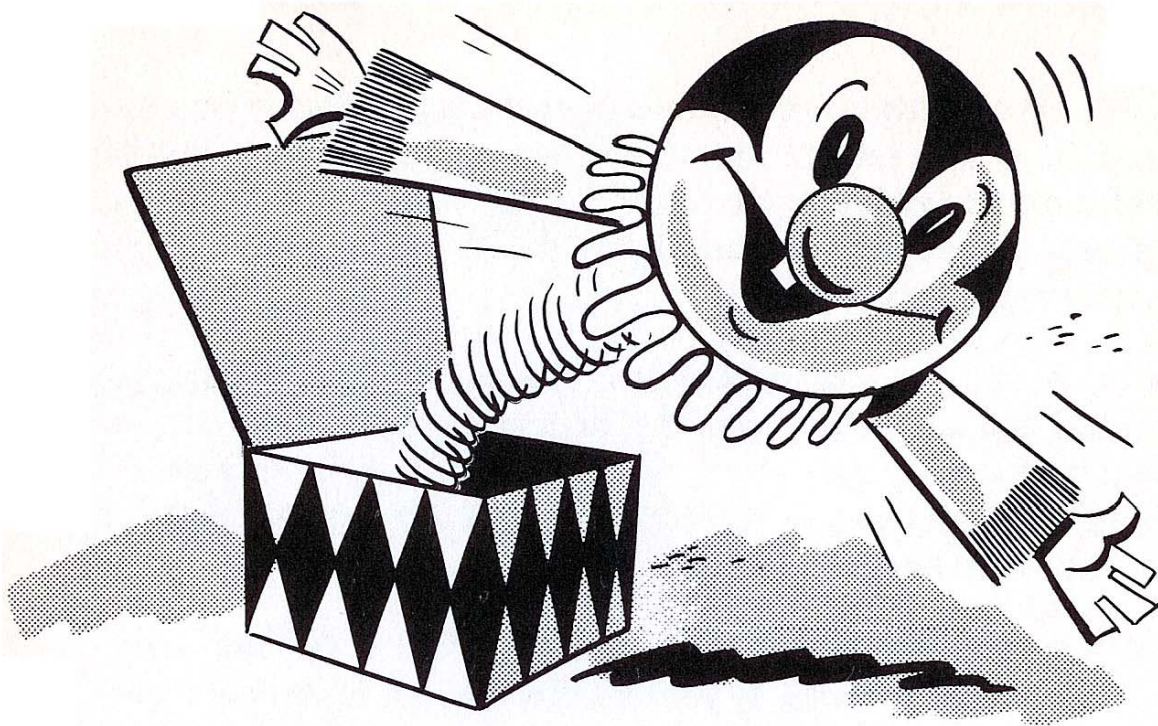

Ten screws secure the air horn to the main body. Eight are of the same length, one is slightly longer, and another is still longer. The medium-length screw is in the counter-bore, and the longer one is on the opposite side. Lift the air horn straight up so you will not damage the floats.

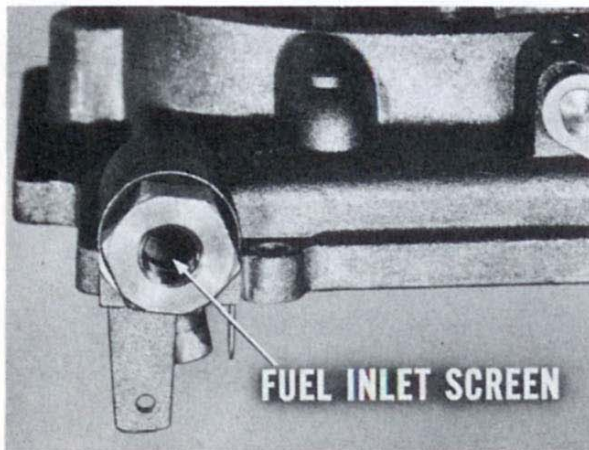

Make a visual inspection for presence of dirt in the float bowls. Then run your finger across the bottom of the float chamber and feel for dirt or foreign particles. If you see or feel any, remove the fuel inlet screen and inspect it for dirt. Inspect the float needle valves and seats, too. If the needles

are damaged, replace them. Clean or replace the screen. If dirt is present in the float bowl, chances are the fuel filter is pretty well filled up, so replace it, too.

This is a good time to inspect the mating surfaces of the air horn and main casting. Nicks and burrs on these surfaces can cause air leaks that might lead to mileage or performance complaints. Dress off rough spots.

Install a new gasket on the air horn, and install the float needles and floats. **Float level on the AFB carburetor has to be measured with the gasket in place.** This differs from the procedures on previous models of the four-barrel carburetor.

Check Float Adjustment. To check float adjustment, sight along the side of the float to see that it is parallel to the edge of the air horn. Parallel alignment is needed to keep the float from rubbing on the side of the float bowl.

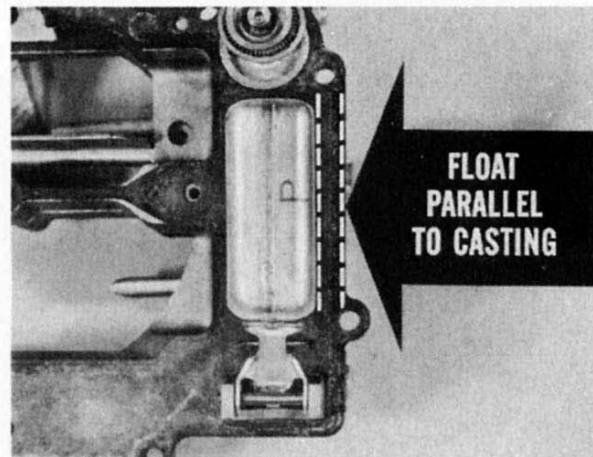

If the float is not parallel to the edge of the air horn you'll have to bend the float lever. Support the lever with your thumb to relieve the strain on the pivot pin, and use your forefinger to bend the float lever.

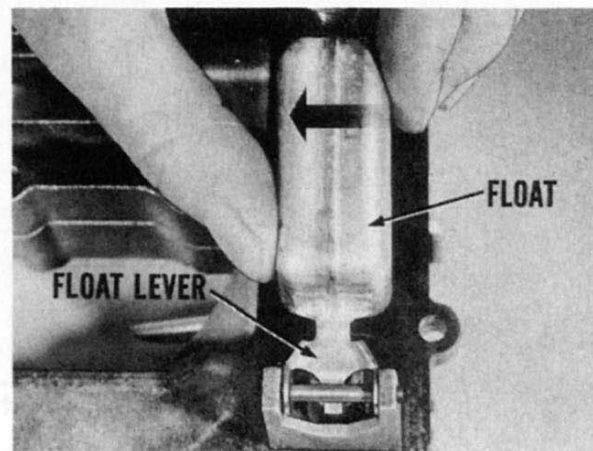

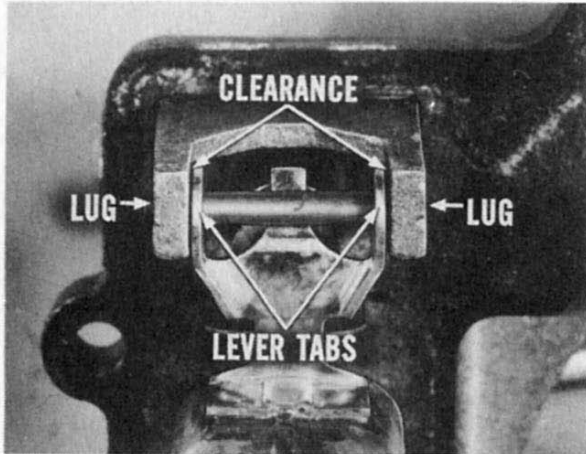

Inspect the clearance between the float lever tabs and the air horn lugs. The float should move freely on the pivot pin, but should not have excessive side movement that would permit it to rub on the sides of the bowl. This side clearance can be controlled by bending the float lever tabs.

With the air horn inverted, and the floats holding the needle valves seated, check the float level.

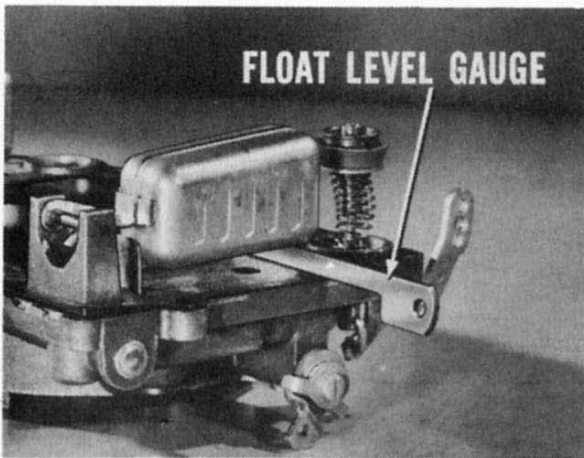

This is measured with the gauge (or a $\frac{7}{32}$ " drill) placed between the outer end of the float and the gasket. If an adjustment has to be made, bend the float lever, close to the float. (Note: The float level for the front carburetor of a dual four-barrel installation is $\frac{9}{32}$ ".)

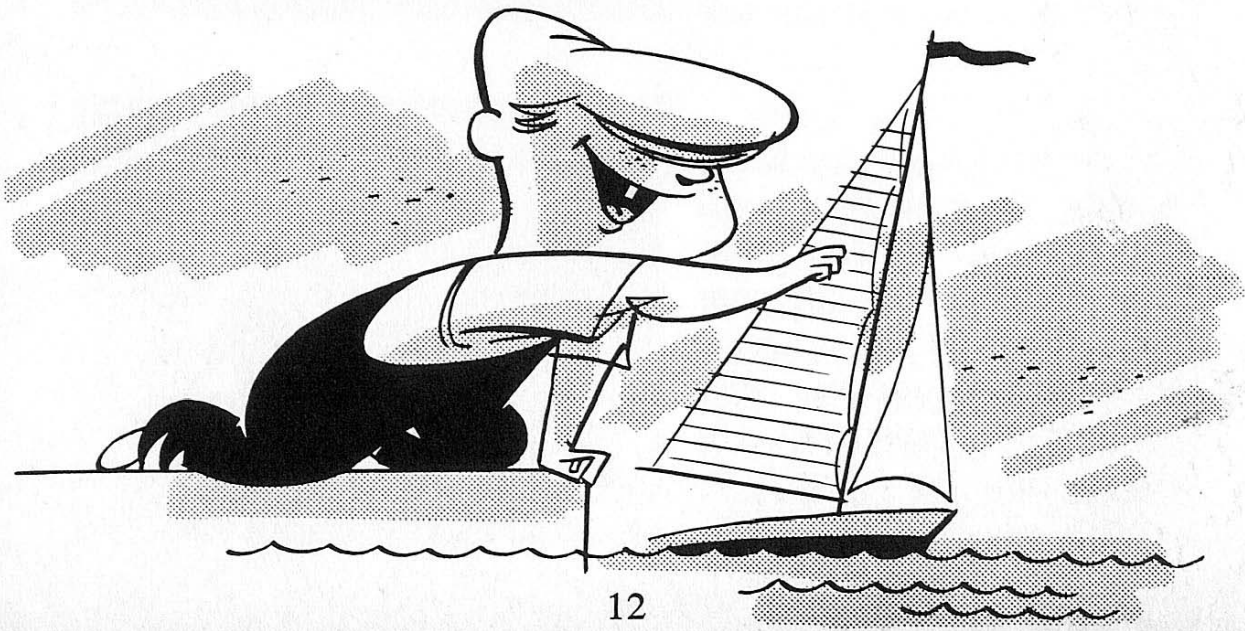

Float drop should be checked next. This is an important adjustment, since it insures that the floats permit the needle valves to open sufficiently to admit an adequate supply of fuel to the bowls. Hold the air horn right side up, with the floats hanging. Measure from the gasket to the outer end of the float. The distance should be $2\frac{3}{32}$ ". If adjustment is necessary, bend the stop tab at the rear of the float lever.

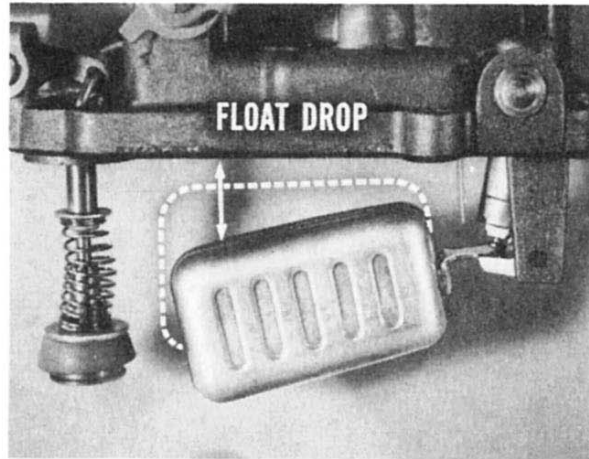

Remove and Install Baffles. Baffles in the float system help to maintain a stable fuel supply for the primary and secondary jets. If the baffles are removed when cleaning the carburetor, it is important that they be installed with the tooth edges toward the center of the bowl. And, when the air horn is assembled to the main body, the small baffles in the horn should slide into place on the bowl side of the float chamber baffles. If not properly installed, the baffles can cause the floats to hang up during operation.

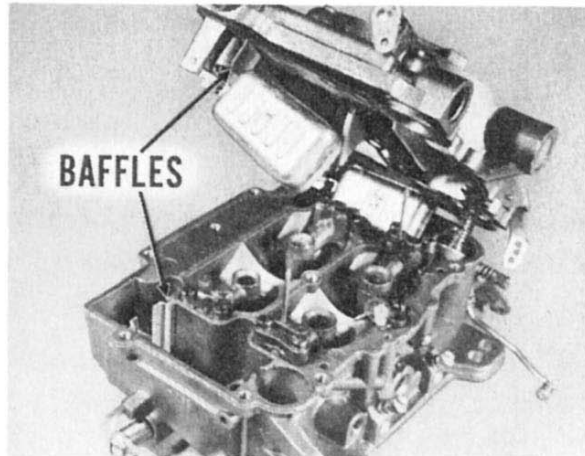

Remove Primary Venturi. As previously mentioned, the primary and secondary venturi assemblies are removable. This is a distinct advantage when it comes to cleaning jets and passages. Remember, the primary venturi contains the idle air bleed, idle jet, high speed nozzle, and main vent tube. Any obstruction in a jet or passage will interfere with fuel flow, and will affect performance. Also, a loose venturi or a damaged venturi gasket will permit an air leak that will upset the air-fuel mixture ratio. This, of course, would have an effect on performance, too.

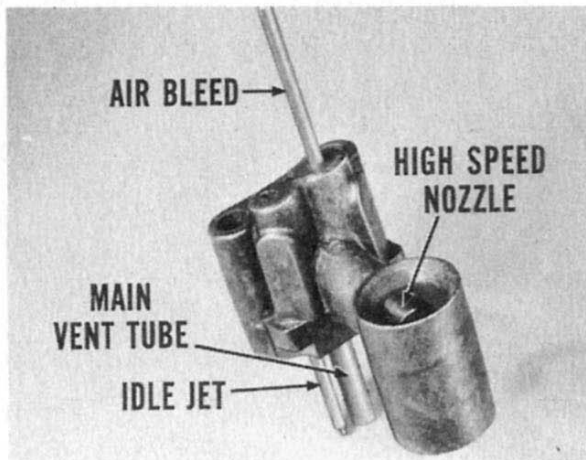

Remove the two screws which hold the primary venturi to the main body and lift out the venturi assembly. Inspect it carefully for presence of dirt, and clean it thoroughly so all passages and jets are free. Discard the gasket, because a new gasket should be used whenever the venturi is installed.

NOTE: Denatured alcohol is a good cleaning solvent. Never use a piece of wire or a drill to clean jets or air bleeds. They will enlarge carefully calibrated openings, and upset the mixture ratio.

Adjust Primary and Secondary Throttle Linkage. Secondary throttle valves are linked mechanically to the primary throttle valves. The secondaries stay closed until the primaries are about $\frac{2}{3}$ rds open. Both valves reach wide-open position at the same time. To adjust the secondary throttle lever, block the choke valve wide open. Sec-

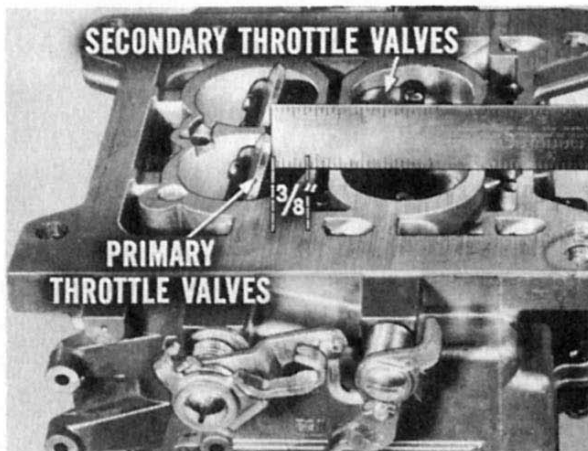

ondary throttle valves should just start to open when the primary throttle valves are open $\frac{3}{8}$ " , measured between the edge of the valve and the bore. (On dual carburetor models 2652S and 2653S, primary throttle valve opening should be $\frac{23}{64}$ ".) If necessary, bend the connecting link to obtain this setting.

Next, back off the idle speed screw to be sure the primary and secondary throttle valves are tightly closed. There should be .010" to .030" between the positive closing shoes on the primary throttle levers. Bend the secondary shoe if necessary, to get this clearance.

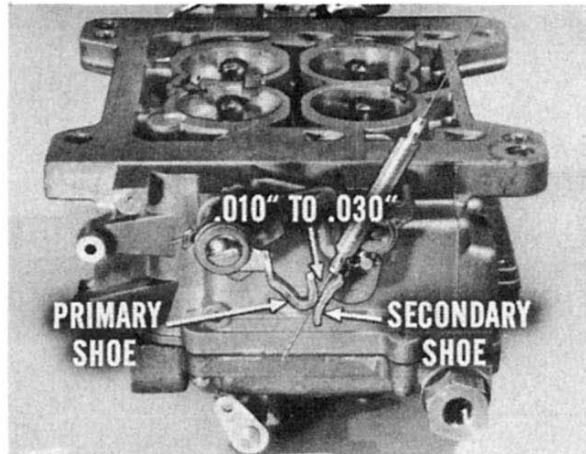

Adjust Secondary Throttle Valve Lock-Out. A secondary throttle valve lock-out, controlled by the choke rod, locks the secondary valves closed until the engine warms up and the choke is fully open. Crack the throttle valves, and manually open and close the choke valve. The tang on the secondary throttle lever should freely engage in the notch of the lock-out dog. If adjustment is needed, bend the tang on the secondary throttle lever.

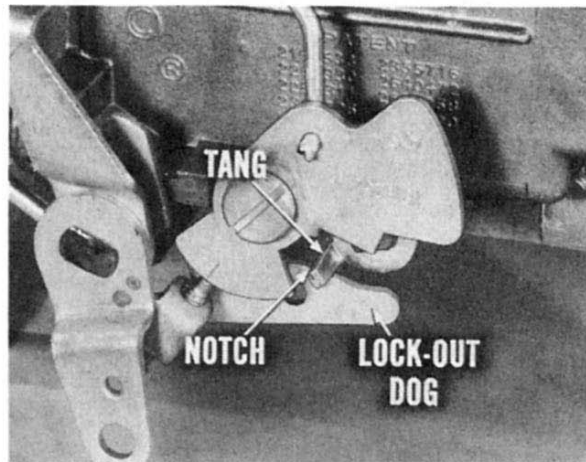

Accelerator pump system

On the AFB carburetor, the accelerator plunger is moved down by a spring. This extends pump discharge time so a continuous stream is supplied rather than one quick squirt.

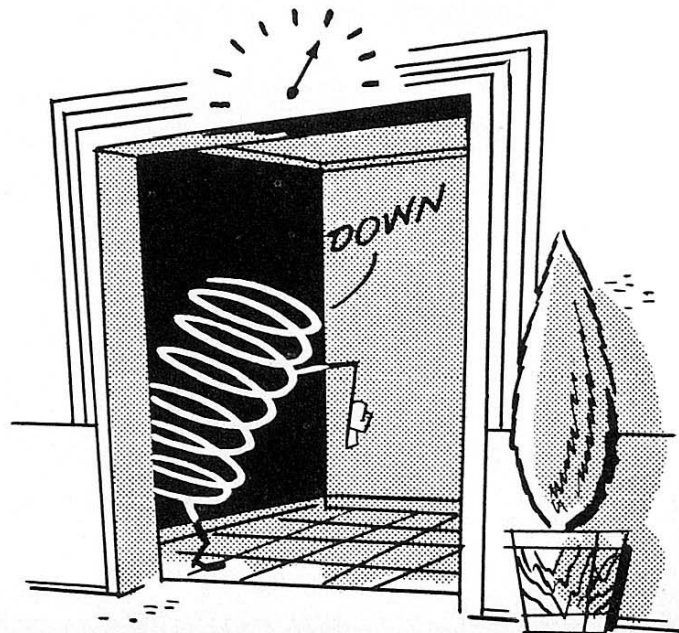

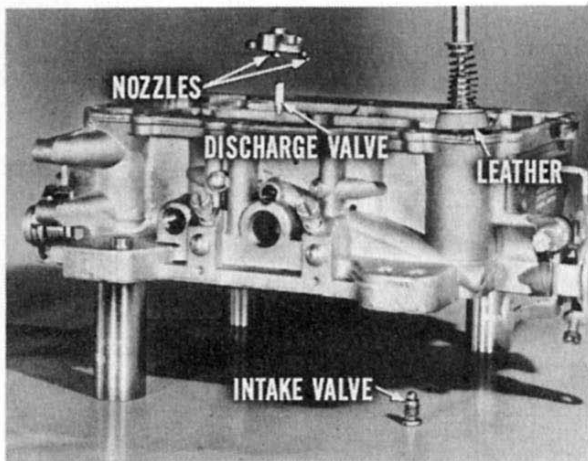

If service is needed, here are the main pump system points to keep in mind: leather in good condition, clean discharge nozzles, and no leakage at intake and discharge check valves. If dirt was found anywhere else, the intake and discharge check valves should be cleaned thoroughly.

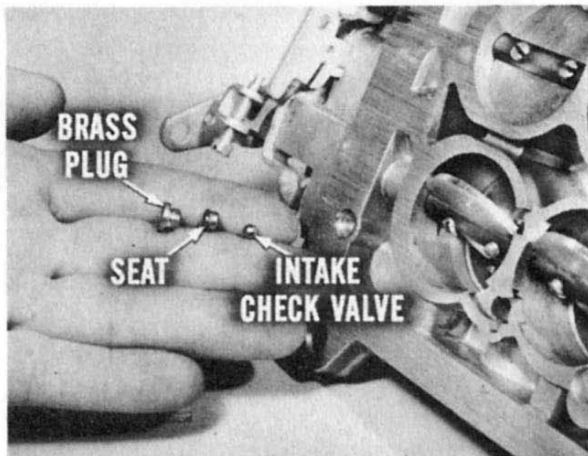

To do that, remove the brass plug, the intake check valve and seat from the bottom. The discharge check valve is under the pump discharge nozzles, which are removable. Clean up the checks and use a new gasket under the nozzles before you re-install the parts.

Adjust Accelerator Pump Stroke. Put the connector in the center

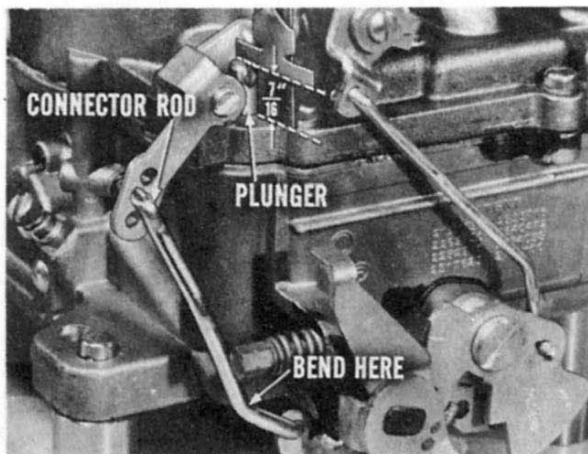

hole of the operating lever. This is the position for normal driving. There should be $\frac{7}{16}$ " from the air horn to the top of the plunger. Bend the connector rod at its lower angle, if needed. The outer hole provides a short pump stroke for summer driving. The inner hole provides a long pump stroke for winter driving.

Choke system

You'll find the choke system operates on only the primary side, since the secondary barrels are locked out when the engine is cold. Two types of automatic choke are used with this AFB carburetor: some use the crossover-type while others use the integral-type.

Adjust Integral-type Choke. Remove the heat tube cap and housing cover. Then, hold the choke valve closed and see if there is .040" clearance between the choke lever and the stop lug in the piston housing.

If you don't have this clearance, bend the choke connector rod. When installing the housing cover, start with the index mark pointing down. Then rotate the housing clockwise until its index mark lines up with the center index mark on the carburetor housing.

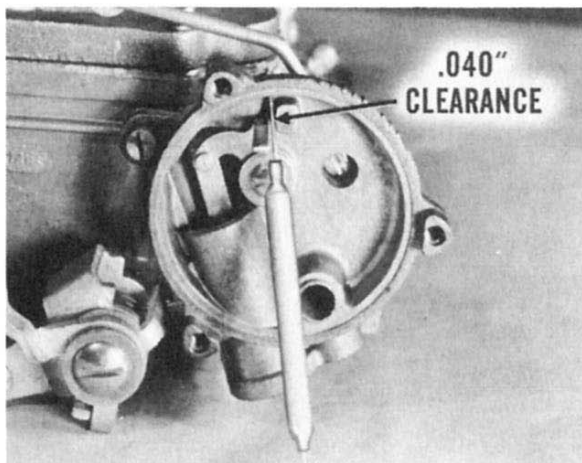

Adjust Crossover-type Choke. Remove the two bolts which hold the choke in its pocket in the manifold. Loosen the shaft nut, and turn the adjusting plate toward "lean" or "rich". You'll find "L" and "R" stamped on the cover. Reinstall the choke in the manifold, and tighten the retaining bolts.

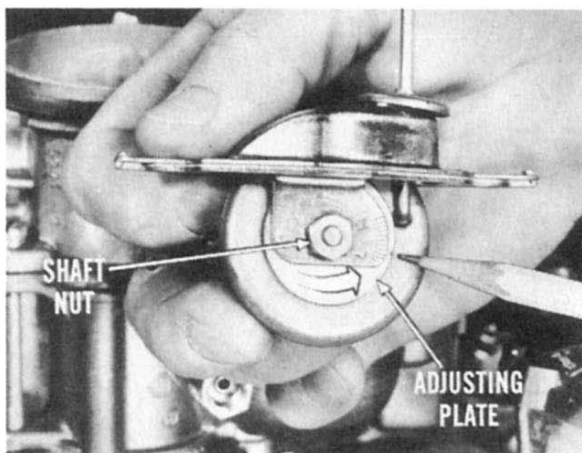

Adjust Fast Idle Cam Linkage. Hold the choke valve closed, and also see that the lugs on the inner and outer choke levers are in contact with each other. With these parts held as described, the end of the

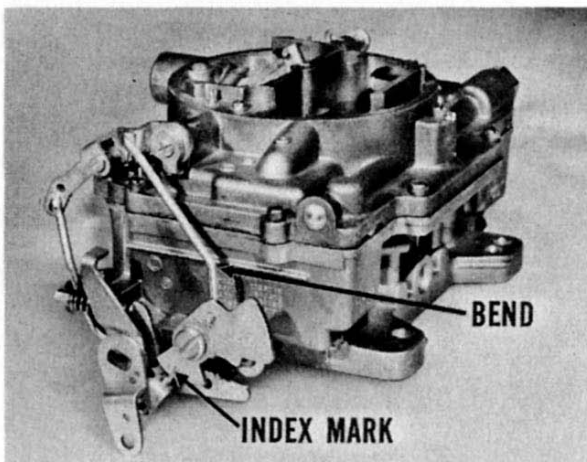

fast idle adjusting screw should be centered on the index mark on the fast idle cam. If it isn't, bend the lower end of the connector rod until it is centered on the mark. Then, in order to get the correct engine r.p.m. for fast idle operation, the fast idle adjusting screw setting will have to be checked.

Adjust Fast Idle Screw. Hold the choke valve closed, being sure the fast idle adjusting screw is at the index mark on the fast idle cam,

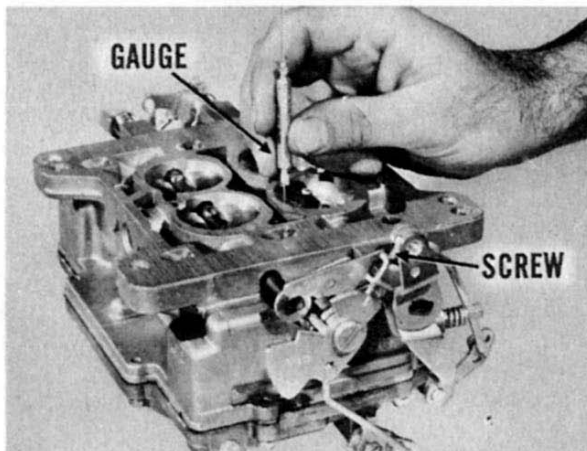

as described in the preceding paragraph. Then, turn the adjusting screw in or out until a .012" wire gauge will pass between the inner edge of the primary throttle valve and the bore of the barrel. With this clearance set at .012", the engine fast idle speed will be 1400 r.p.m.

Check this clearance at both throttle valves to be sure it is the same. If it isn't it may be necessary to reposition the throttle valve on the shaft, or replace the throttle shaft and both valves.

Adjust Choke Unloader. Hold the throttle valves wide open. Close the choke valve until the fast idle cam touches the unloader lug on the throttle lever. At this instant there should be a $\frac{1}{4}$ " opening between the inner edge of the choke valve and the bore. Bend the unloader lug on the throttle lever if an adjustment is needed.

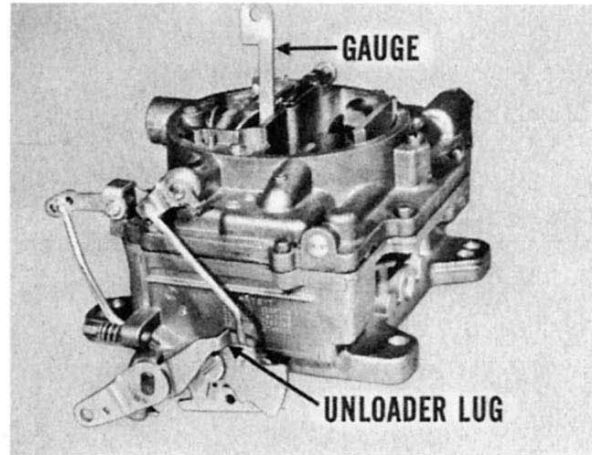

Engine idle adjustments

When adjusting engine idle speed and mixture, the engine should be at operating temperature. The idle speed should always be set first, and then the mixture adjusted.

Adjust Idle Speed. With a tachometer connected to the engine, turn the idle speed adjusting screw to 500 r.p.m.

Adjust Idle Mixture. There are two idle mixture adjusting screws, each screw controlling one of the primary barrels. After setting the speed at 500 r.p.m., adjust the idle mixture screws. Turn both mixture screws in $\frac{1}{8}$ th turn at a time, observing the smoothness of engine performance. If the engine runs rougher, turn the screws out. When you have both screws set at the point where the engine runs best, try turning one screw at a time in an attempt to improve the performance. You'll probably have to reset the idle speed screw several times while making the mixture adjustment, to hold the speed at 500 r.p.m.

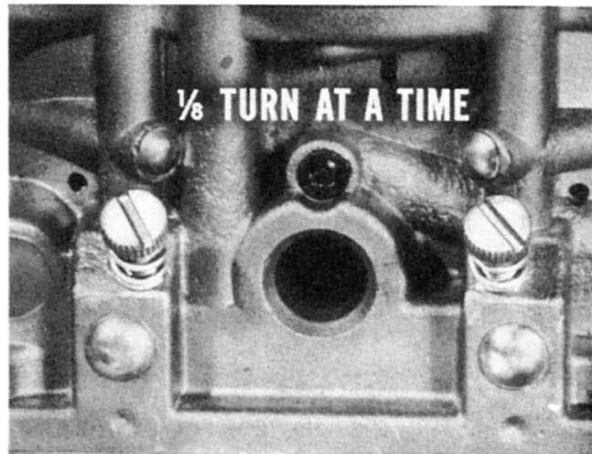

MODELS USING DUAL AFB CARBURETORS

Some Plymouth, Dodge, and De Soto models are equipped with two AFB-type carburetors. Carburetion on these cars is *progressive*. The two primary barrels of the rear carburetor supply fuel for part-throttle, low speed operation. The two secondary barrels of the rear carburetor open next. Then the two primary barrels of the front unit open, and finally, the two secondary barrels of the front unit open. At high speeds, all four pairs of throttle valves reach wide-open position at the same time.

LET'S PLAY FOLLOW-THE-LEADER



On cars equipped with dual AFB carburetors, a model 2653S carburetor having an integral type choke is used at the rear. Service adjustments are the same as for other models. The front carburetor, model 2652S, should have its float level set at $\frac{9}{32}$ " instead of $\frac{7}{32}$ ". On both of these carburetors, the secondary throttle valves should start to open when the primary valves are open $\frac{23}{64}$ ".

Velocity Valves. Both the front and rear carburetor have offset valves above the secondary throttle valves to control secondary barrel operation. These air velocity-operated valves are commonly called “auxiliary throttle valves.” Counterweights hold them in closed position. They open when the force of the air against them is great enough to lift the counterweights. They should operate freely, but no adjustment is required.

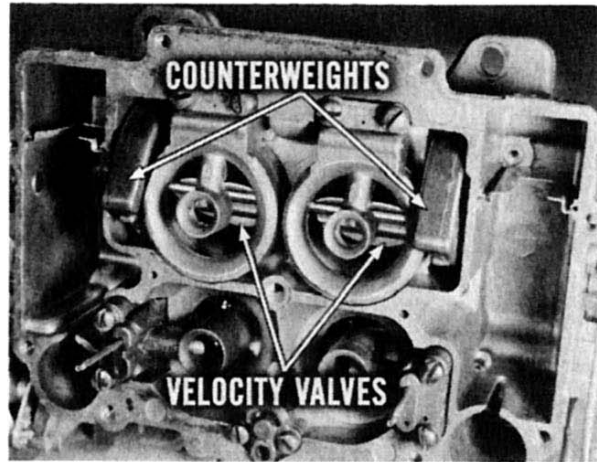

Air Bypass Screw. These carburetors do not have the conventional idle speed adjusting screw. You adjust idle speed by turning an air bypass screw located between the two idle mixture adjusting screws. This screw controls air bypassed from the air horn to an opening below the throttle blades. Opening the screw increases engine speed. Closing the screw reduces air flow, richens the mixture, and reduces speed. Initial setting for the air bypass screw should be two turns open. Initial setting for the idle mixture screws is one turn open.

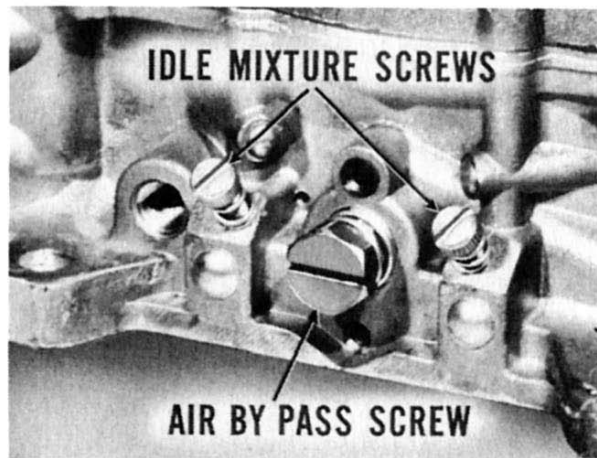

Final Adjustments On Car. Handling the final adjustment of dual AFB carburetors is simple enough if you follow the various steps in the proper order. The first thing you'll have to do is to adjust the throttle connector rod so that the throttles of the two carburetors

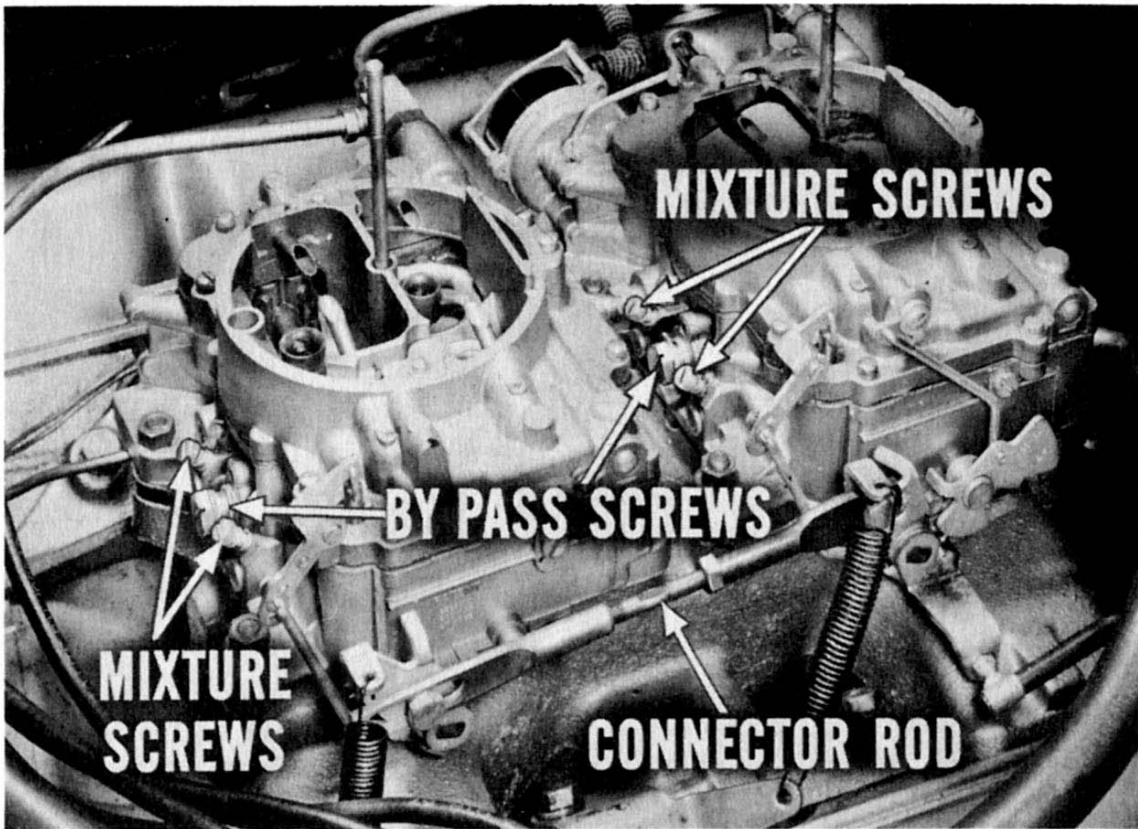

are properly synchronized. Next, you'll have to adjust the air bypass screws and idle mixture screws to get an engine idle speed of 600 r.p.m. and the smoothest possible idle operation. Here's how you go about it.

Adjust Throttle Connector Rod. Remove both throttle lever return springs. Block throttle valves of the rear carburetor wide open.

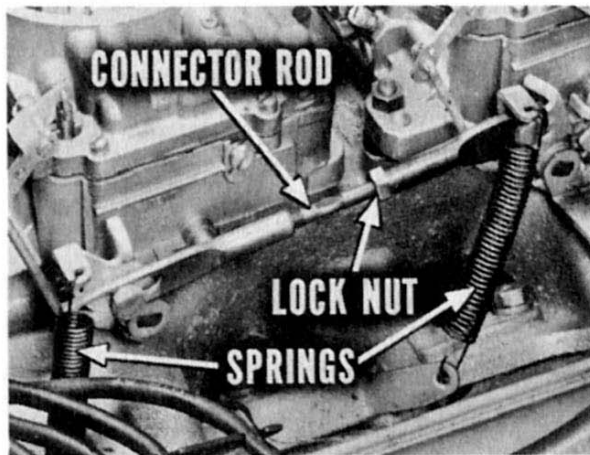

Loosen the connector rod lock nut. Turn the threaded rod until the throttle valves of the front carburetor are also wide open. Tighten the lock nut and reconnect the lever return springs. Recheck action so you're sure the throttle valves of both carburetors reach wide-open position at the same time.

Adjust Idle Speed, Idle Mixture. See that air bypass screws are open two turns, idle mixture screws of both carburetors are open one turn. Start and warm up the engine. This setting will provide an initial idle speed faster than 600 r.p.m., and prevent stalling during warm up. Turn both air bypass screws clockwise about ½ turn. Engine speed will decrease to about 600 r.p.m. If not, turn each screw *in* a little more. If speed drops below 600 r.p.m., turn both screws out a little to get the 600 r.p.m. idle speed setting.

Adjust both idle mixture screws of the rear carburetor ⅛ turn at a time until engine runs smoothly. Do this on the front carburetor mixture screws next. Always complete adjustment of *both* idle mixture screws on *one* carburetor before adjusting the idle mixture screws on the other. When you get the smoothest engine idle, speed may increase above 600 r.p.m. Turn both air bypass screws *in* the same amount until you get the 600 r.p.m. speed. Finally, adjust the idle mixture screws of both carburetors to get more smoothness.

NOW . . . KEEP UP YOUR GOOD WORK!

This wraps up the story on AFB carburetors. So far, you've all done a lot to help us maintain our reputation for doing good service work. Since you're gonna see a lot of four-barrel carburetors in the coming months, this is another opportunity to keep up the good work. The tips outlined in this reference book will help you add to our large service following.

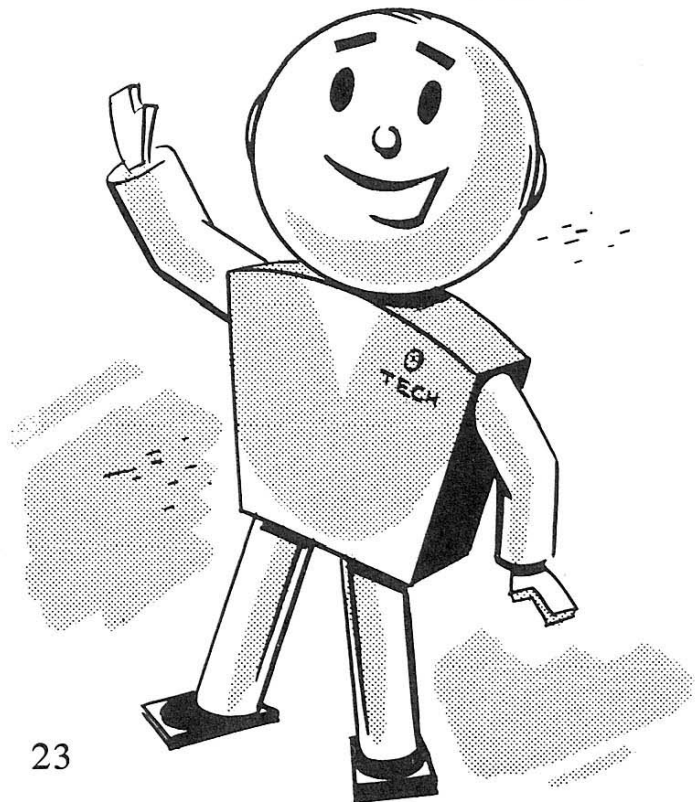

**RECORD YOUR ANSWERS
TO THESE QUESTIONS
ON QUESTIONNAIRE NO. 121**

During disassembly, keep each float, its needle valve and seat assembly together so they can be reinstalled in their original locations.

RIGHT

1

WRONG

When removing the carburetor from the engine, drain the fuel from both float bowls.

RIGHT

2

WRONG

Always install a new air horn-to-body gasket when you reassemble the carburetor.

RIGHT

3

WRONG

Float level on the AFB carburetor must be measured with the gasket in place.

RIGHT

4

WRONG

Besides float level, float alignment, side-play, and float drop should be checked.

RIGHT

5

WRONG

Use a wire or drill to clean out plugged jets or air bleeds.

RIGHT

6

WRONG

Secondary throttle valves, linked mechanically to the primary throttle valves, stay closed until the primaries are about $\frac{2}{3}$ open.

RIGHT

7

WRONG

Secondary throttle valves should just start to open when the primary throttle valves are open $\frac{3}{8}$ " measured between the edge of the valve and bore.

RIGHT

8

WRONG

A secondary throttle valve lock-nut controlled by the choke rod, locks the secondary valves closed until the engine warms up and the choke is fully open.

RIGHT

9

WRONG

To adjust accelerator pump travel, put the connector rod in the center hole, and see if there is $\frac{1}{16}$ " between the top of the bowl cover and the top of the plunger.

RIGHT

10

WRONG

Litho in U.S.A.